



## BMR320

### 8:1 fixed ratio digital IBC (400W)

BMR320 is based on an unregulated and non-isolated topology, and is intended for applications needing a lower voltage intermediate bus for improved system efficiencies such as AI and Cloud Computing.

BMR320 delivers an efficiency of 97.6% at half load, and offers a PMBus compatible digital interface, and is supported by our Flex Power Designer tool.

Up to 3 units can be used in parallel to supply an overall output power of up to 1080W.



### Key features

- 8:1 fixed ratio IBC
- Small form factor
- Parallelable - up to 3 units
- Unregulated
- Non-isolated
- Digital interface with PMBus
- Excellent price/performance ratio

### Soldering methods

- Pb Free SMD reflow

### Target key electrical information

Parameter	Values
Input range	40 - 60V
Output voltage	5 - 7.5V
Output current continuous	60A at 54V <sub>in</sub>
Output power continuous	400W

### Mechanical

27.0 x 18.0 x 6.4 mm / 1.06 x 0.71 x 0.25 in

### Application areas

- Designed for Artificial Intelligence (AI) applications

## Product options

The table below describes the different product options.

Example: BMR320 1 0 00 /001						C	Definitions
<b>Product family</b>	BMR320						
<b>Pin length options</b>		1					0 = Pin length TBD 1 = SMD
<b>Baseplate / HS option</b>			0				0 = No baseplate
<b>Other hardware options</b>				00			00 = Standard variant 01 = TBD
<b>Configuration code</b>					/001		/001 = standard config. for 40-60 V <sub>in</sub>
<b>Packaging options</b>						C	C = Tape on Reel H = hard tray, dry pack

For more information, please refer to Part 3 Mechanical information.

## Part 1: Electrical specifications

### Absolute maximum ratings

Stress in excess of our defined *absolute maximum ratings* may cause permanent damage to the converter. Absolute maximum ratings, also referred to as *non-destructive limits*, are normally tested with one parameter at a time exceeding the limits in the electrical specification.

Characteristics	min	typ	max	Unit
Operating temperature ( $T_{PI}$ )	-40		85	°C
Storage temperature	-55		125	°C
Input voltage ( $V_{in}$ )	-0.3		60	V
Isolation voltage (input to output)	0		0	V
5V $V_{CC}$	-0.3		5.5	V
Enable control pin voltage	-0.3		$V_{CC}+0.3$	V
PMBus pins	-0.3		$V_{CC}+0.3$	V

### Reliability

Failure rate ( $\lambda$ ) and mean time between failures ( $MTBF = 1/\lambda$ ) are calculated based on *Telcordia SR-332 Issue 4: Method 1, Case 3, (80% of  $I_{out\_TDP}$ ,  $T_{PI}=40^{\circ}C$ , Airflow=200 LFM)*.

	Mean	90% confidence level	Unit
Steady-state failure rate ( $\lambda$ )	108	142	nfailures/h
Standard deviation ( $\sigma$ )	26.3		nfailures/h
MTBF	9.24	7.04	MHr

### Typical application diagram

Capacitor values are defined in the Electrical Specification tables. The EMI filter is defined in the EMC Part 2.

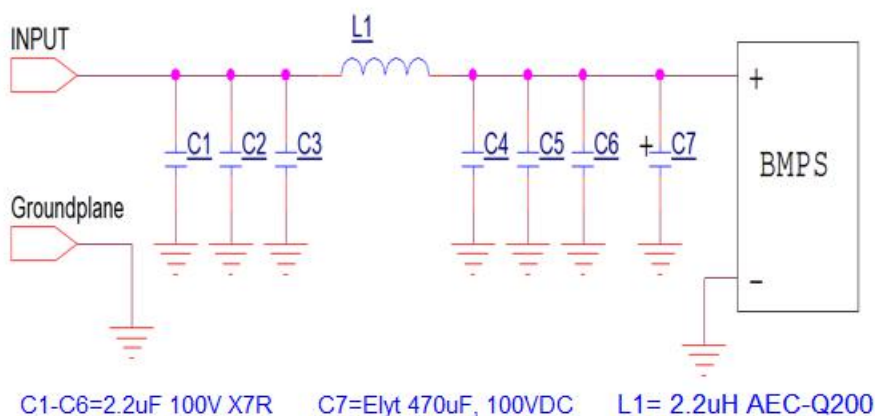

**Electrical specifications for BMR320****6.7 V, 60 A  $\leq$  400 W**

Min and Max values are valid for:  $T_{P1} = -40$  to  $+85^{\circ}\text{C}$ ,  $V_{in} = 40$  to  $60$  V, unless otherwise specified under conditions. Typical values given at:  $T_{P1} = +25^{\circ}\text{C}$ ,  $V_{in} = 54$  V, max  $P_{out\_TDP}$ , unless otherwise specified under conditions, see Note 1.

Additional external  $C_{in} = 220$   $\mu\text{F}$ ,  $C_{out} = 1$  mF

Characteristic	conditions	minimum	typical	maximum	unit
<b>Key features</b>					
Efficiency ( $\eta$ )	50% of $P_{out\_TDP}$		97.6		%
	100% of $P_{out\_TDP}$		96.5		%
	50% of $P_{out\_TDP}$ $V_{in} = 40\text{V}$		96.9		%
	100% of $P_{out\_TDP}$ $V_{in} = 40\text{V}$		95.7		%
$P_{out\_TDP}$ thermal design power (TDP)	See Note 1			400	W
Recommend capacitive load		110		5000	$\mu\text{F}$
Power Loss	50% of $P_{out\_TDP}$		5.5		W
	100% of $P_{out\_TDP}$		14		W
	50% of $P_{out\_TDP}$ $V_{in} = 40\text{V}$		6.1		W
	100% of $P_{out\_TDP}$ $V_{in} = 40\text{V}$		22		W
<b>Input characteristics</b>					
Input voltage range ( $V_{in}$ )		40	54	60	V
Input OVP		63	64	65	V
Recommended external input capacitance		47		470	$\mu\text{F}$
<b>Output characteristics</b>					
Output voltage initial setting and accuracy	$P_{out} = 0$ W	5	6.7	7.5	V
Output current ( $I_{out}$ )	$V_{in} = 40 - 60$ V	0	60	80	A
Max start-up load	Max load			5	A
Load transient voltage deviation	See Note 2		$\pm 200$		mV
Load transient recovery time	See Note 2		5		ms
Output ripple & noise	max $P_{out\_TDP}$			50	$\text{mV}_{p-p}$

Note 1: Max. output current is rated at 60 A at 54V in. Max power is  $\leq 400\text{W}$  and continuous power (thermal design power (TDP)) is  $\leq 400$  W depending on thermal conditions.

Note 2: Load step 25-75-25% of max  $P_{out\_TDP}$   $di/dt = 1$  A/ $\mu\text{s}$ .

**Electrical specifications for BMR320**6.7 V, 60 A  $\leq$  400 W

Characteristic	conditions	minimum	typical	maximum	unit
<b>On/off control</b>					
Turn-off input voltage	Decreasing input voltage		35.5		V
Turn-on input voltage	Increasing input voltage		37		V
Minimum enable activate time from 5V VCC applied		50			ms
Ramp-up time (from 10–90% of V <sub>out</sub> )			8		ms
Enable start-up time				20	ms
Logic high: trigger level	Voltage Rising			0.7	V
Logic low: trigger level	Voltage Falling	0.6			V
Logic high: response time			0.5		ms
Sink current			0.35		mA
<b>Protection features</b>					
Output current limit (OCP) response and type	Slow (Fast) Latching	85	90 (240)	100	A
Output overvoltage protection (OVP)			7.9		V
Output overvoltage protection (OVP) response and type	Latching			100	us
Over temperature protection (OTP)			125		°C
Over temperature protection (OTP) response and type				100	us
<b>5.0 V Vcc Auxiliary power</b>					
Voltage		4.5	5.0	5.5	V
Current	Note 1			200	mA

Note 1: In standby, the current draw is approximately 20 mA.

**Electrical specifications for BMR320 1000/001****6.7 V, 60 A (80 A) ≤ 400 W**

In the table below all PMBus are written in capital letters.

$T_{P1} = -40$  to  $+125$  °C,  $V_{in} = 40$  to  $60$  V, unless otherwise specified under conditions.

Typical values given at:  $T_{P1} = +25$  °C,  $V_{in} = 54$  V, max  $P_{out\_TDP}$ , unless otherwise specified under conditions

Command	Conditions	minimum	typical	maximum	Unit
<b>Monitoring accuracy</b>					
Input voltage READ_VIN			±0.3	±2	V
Output voltage READ_VOUT			±80	±250	mV
Output current READ_IOUT			±1.5	±5	A
Temperature READ_TEMPERATURE_1	See Note 1		±1	±5	°C

Note 1: Depends on cooling type and thermal resistance.

Note 2: Below 0° C the temperature telemetry readings deviation is higher and not possible to read temperature lower then -22°C

For more detailed information please refer to Technical Reference Document: PMBus commands.

This product is supported by the [Flex Power Designer tool](#).

**Electrical graphs for BMR320 1000/001**

6.7V, 60A (80A)  $\leq$ 400W

**Efficiency**

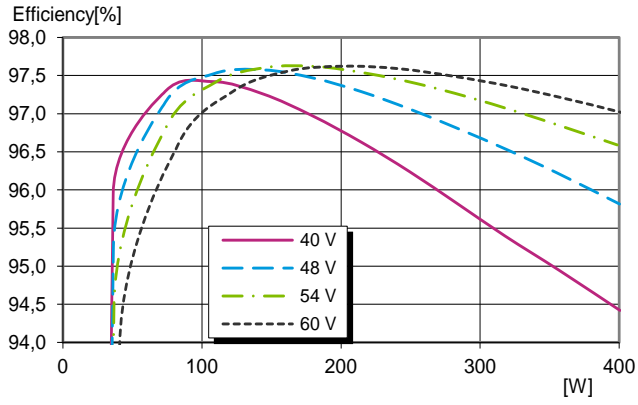

**Power dissipation**

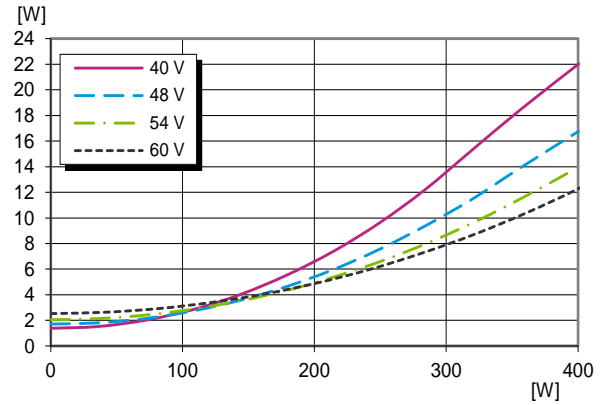

## Part 2: EMC

### Optional external filter for Class B

Suggested external input filter in order to meet Class B in EN 55022 / EN 55032, CISPR 22 / CISPR 32 and FCC part 15J.

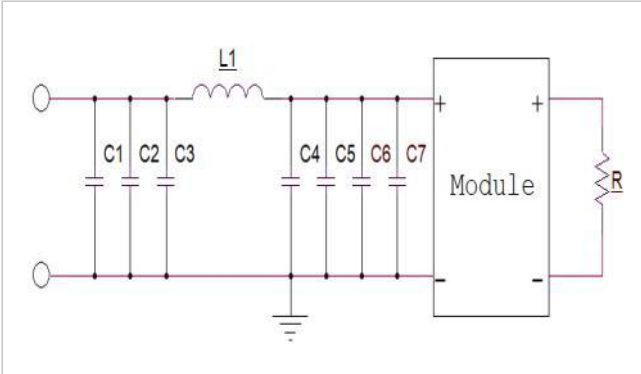

Filter components:

C1-C6 2.2uF 10% 1210 100V X7R, capacitor

C7 470uF 100VDC 20%, Electrolite capacitor

L1 2.2uH 20% 12A DC, Inductor

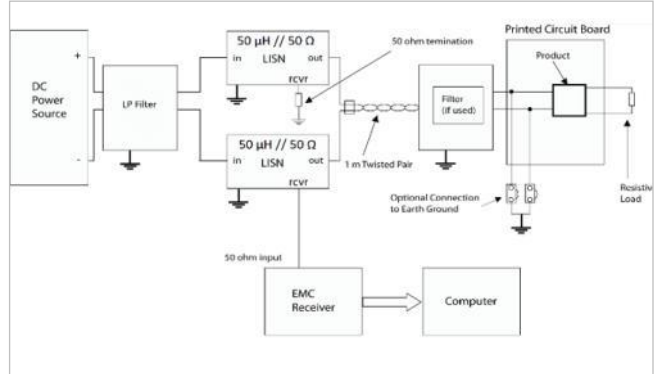

Test set-up

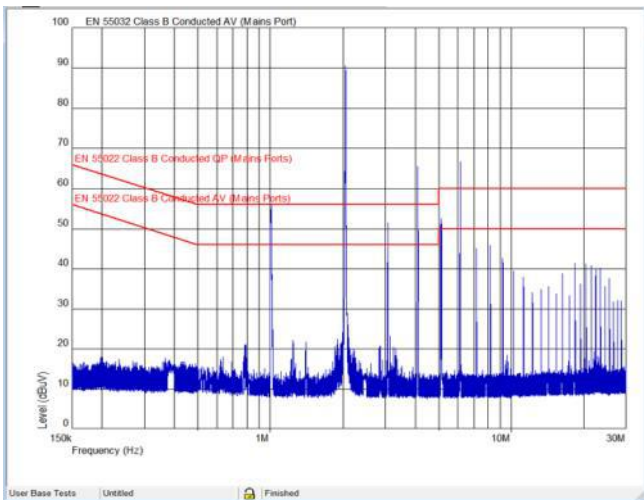

Without EMC filter,  $V_{in} = 54\text{ V}$ ,  $\max P_{out\_IDP}$

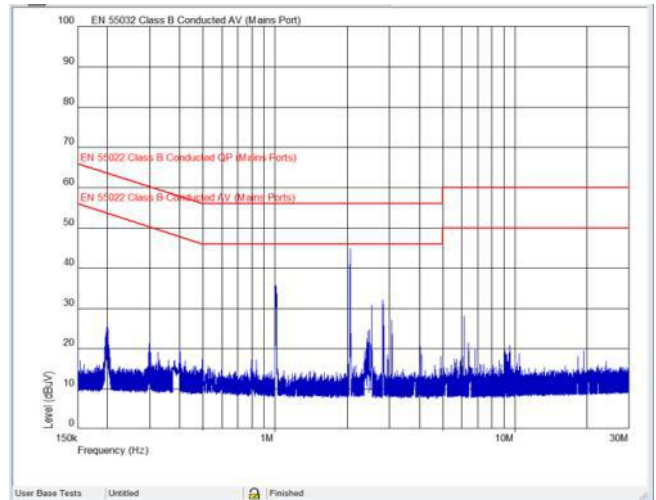

With EMC filter,  $V_{in} = 54\text{ V}$ ,  $\max P_{out\_IDP}$

## Part 3: Mechanical information

### BMR320 xxxx/xxx: surface mounted

Bottom view

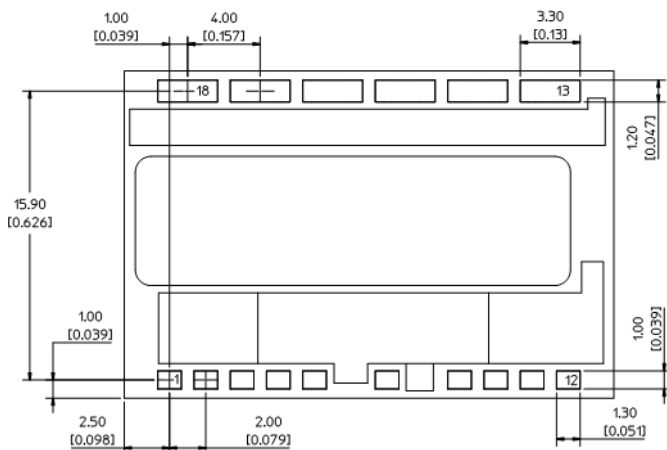

Side view

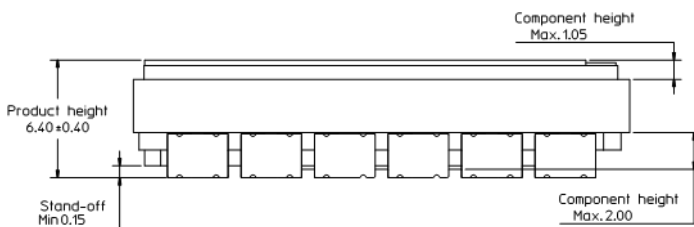

#### Pins

Material: Copper alloy

Plating: Min 0,1  $\mu\text{m}$  Au over 2  $\mu\text{m}$  Ni

Module weight: typical 9.3 g

All dimensions in mm [inches]

Tolerances unless specified:

x.x  $\pm 0.5$  mm [0.02 inch]

x.xx  $\pm 0.25$  mm [0.01 inch]

(not applied on footprint or typical values)

Note: Max pull force 6N, this applies for an orthogonal force widespread over the whole ferrite surface

**Top View - Recommended footprint all variants showing pin positions**

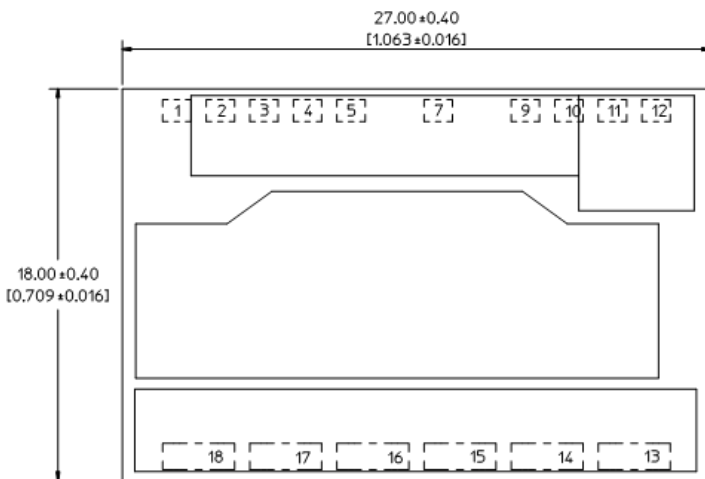
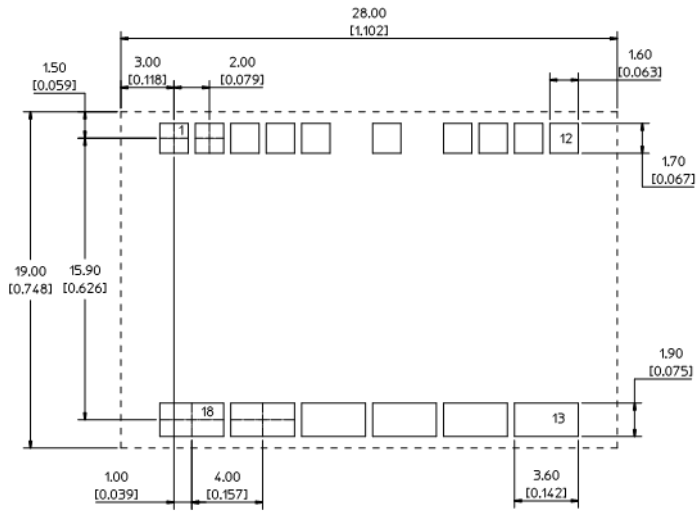

Pin	Designation
1	Not connected
2	SCL
3	SDA
4	GND
5	ADDR
6	Not mounted
7	VIN
8	Not mounted
9	5V Vcc

Pin	Designation
10	Not connected
11	ON/OFF
12	PGOOD
13	Vout+
14	GND
15	Vout+
16	GND
17	Vout+
18	GND

## Part 4: Thermal considerations

The products are designed to operate using a heatsink mounted on top of the device.

### General

For products mounted on a PWB with a heatsink attached, cooling is achieved both by conduction, from the pins to the host board, and through the heatsink mounted on top of the device. The wind speed and temperature are measured in a point upstream the device. The output current derating graphs found later in this section provide the available output current vs. ambient air temperature and air velocity at  $V_{in} = 54$  V.

For products using any form of heatsink structure a top spacing board and side airflow guides are used to ensure airflow hitting the module and not diverted away.

Distance between the tested device and the top space board and the side airflow guides are  $6.35 \text{ mm} \pm 1 \text{ mm}$ .

The product is tested on a  $200 \times 200 \text{ mm}$ ,  $105 \mu\text{m}$  (3 oz), 6-layer test board mounted vertically in a wind tunnel.

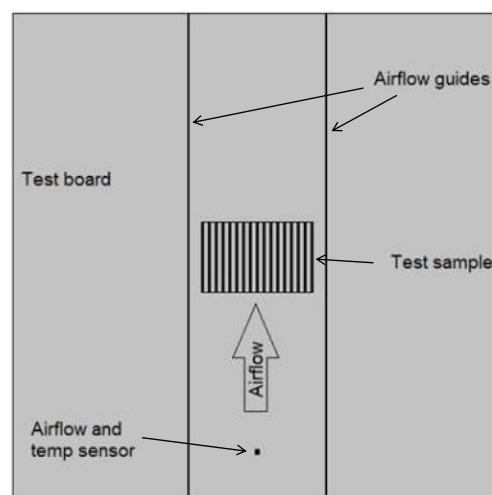
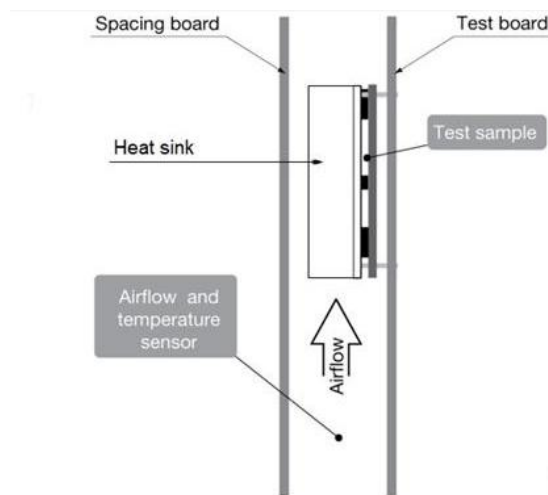

## Part 4: Thermal considerations

**Definition of product operating temperature**

Proper thermal conditions can be verified by measuring the temperature at position P1 as shown below. The temperature at this position ( $T_{P1}$ ) should not exceed the maximum temperatures in the table below. The number of measurement points may vary with different thermal design and topology. Temperatures above maximum  $T_{P1}$ , measured at the reference point P1 are not allowed and may cause permanent damage.

Position	Description	Max. Temp.
P1	PWB TOP side	$T_{P1} = 125\text{ }^{\circ}\text{C}$

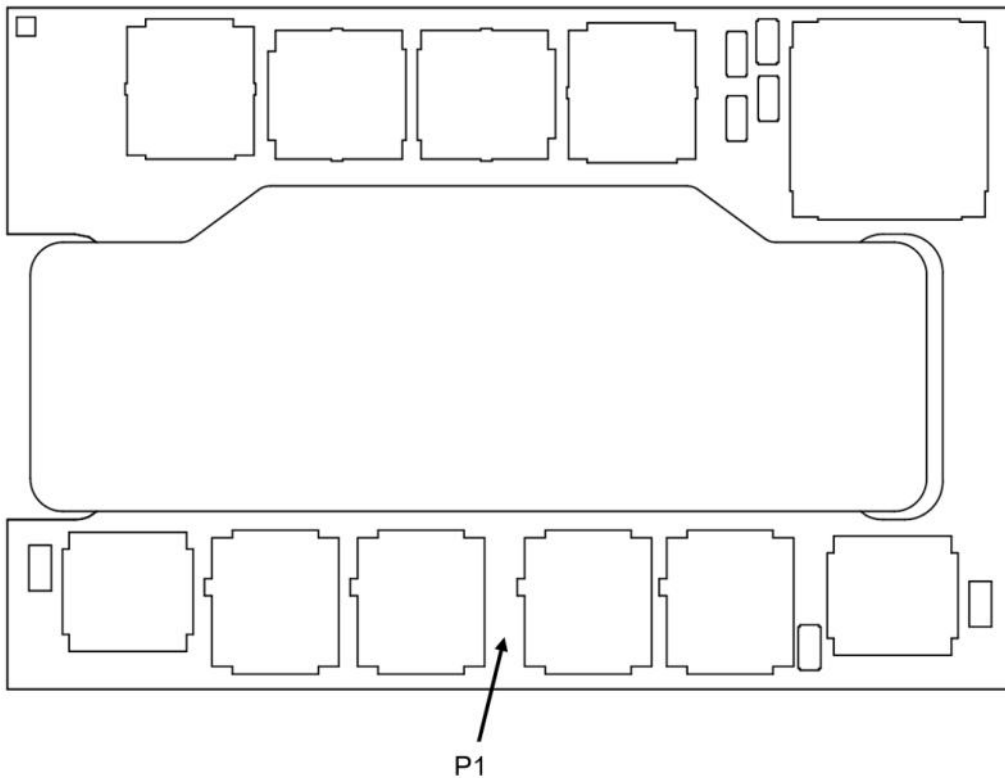
**TOP view**

## Thermal graphs

### Output power derating

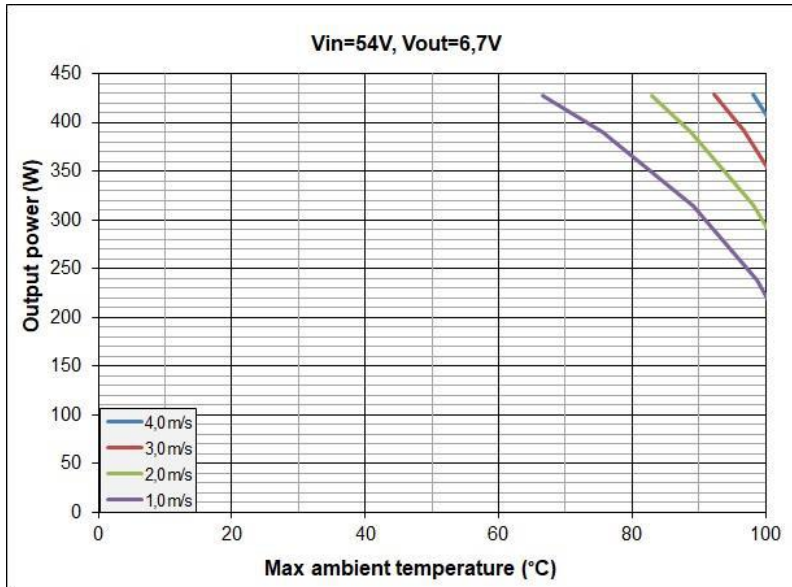

Device with 4.7 K/W thermal resistance heat sink.

## Part 5: Packaging

### Packaging information

The surface mount products are delivered in an antistatic carrier tape (Jedec design EIA 481 standard).

Carrier Tape Specification	
Material	Antistatic PS
Surface resistance	$10^7 < \text{ohm/square}$
Bakability	Tape cannot be baked
Tape width, W	56 mm [2.2 inch]
Pocket pitch, $P_1$	28 mm [1.1 inch]
Pocket depth, $K_0$	7.75 mm [0.287 inch]
Reel diameter	380 mm [15 inch]
Reel capacity	200 products /reel
Reel weight	2.3 kg/full reel

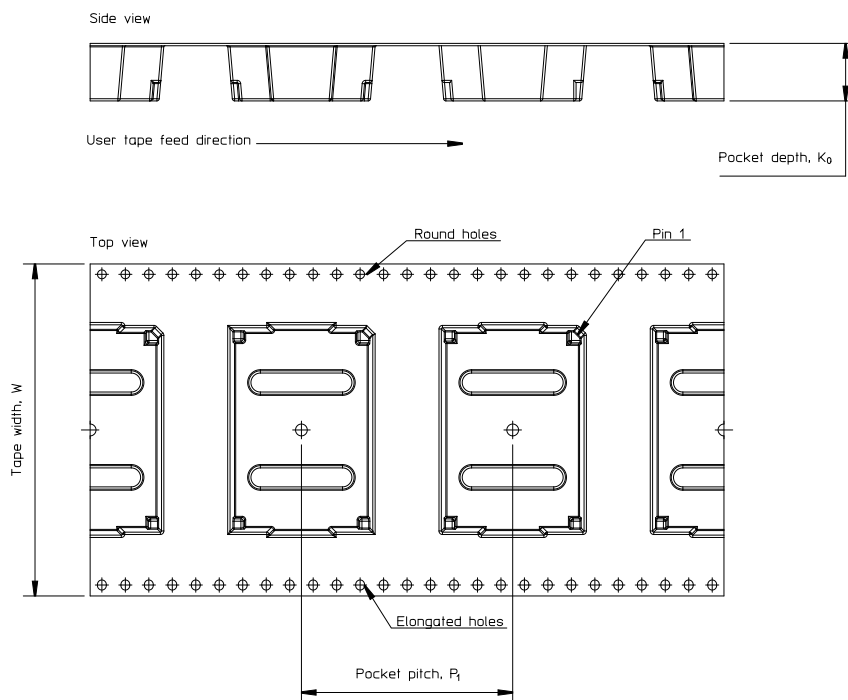

## Part 6: Revision history

### Revision table

Revision number	revision change	date	revisor
Rev. A	New document	2023-04-19	karasell
Rev. B	Updated footer	2023-04-19	kartwaer
Rev. C	Added note info on page 9	2023-05-08	kartwaer

© Flex Power Modules 2023

The information and specifications in this technical specification is believed to be correct at the time of publication. However, no liability is accepted for inaccuracies, printing errors or for any consequences thereof. Flex reserves the right to change the contents of this technical specification at any time without prior notice.

# flex<sup>®</sup>

Flex Power Modules, a business line of Flex, is a leading manufacturer and solution provider of scalable DC/DC converter primarily serving the data processing, communications, industrial and transportation markets. Offering a wide range of both isolated and non-isolated solutions, its digitally-enabled DC/DC converters include PMBus compatibility supported by the powerful [Flex Power Designer](#).



## TECHNICAL REFERENCE DOCUMENT: GENERAL INFORMATION

### Compatibility with RoHS requirements

The products are compatible with the relevant clauses and requirements of the *RoHS directive 2011/65/EU* and *2015/863* have a maximum concentration value of 0.1% by weight in homogeneous materials for lead, mercury, hexavalent chromium, PBB, PBDE, DEHP, BBP, DBP, DIBP and of 0.01% by weight in homogeneous materials for cadmium.

Exemptions in the RoHS directive utilized in Flex Power Modules products are found in the Statement of Compliance document.

Flex Power Modules fulfills and will continuously fulfill all its obligations under regulation (EC) No 1907/2006 concerning the registration, evaluation, authorization and restriction of chemicals (REACH) as they enter into force and is through product materials declarations preparing for the obligations to communicate information on substances in the products.

### Quality statement

The products are designed and manufactured in an industrial environment where quality systems and methods like [ISO 9001](#), [ISO 14001](#), [ISO 45001](#), *Six Sigma*, and *SPC* are intensively in use to boost the continuous improvements strategy. Infant mortality or early failures in the products are screened out and they are subjected to an ATE-based final test. Conservative design rules, design reviews and product qualifications, plus the high competence of an engaged workforce, contribute to the high quality of the products.

### Warranty

Warranty period and conditions are defined in *Flex Power Modules' General Terms and Conditions of Sales*.

### Limitation of Liability

Flex Power Modules does not make any other warranties, expressed or implied including any warranty of merchantability or fitness for a particular purpose (including, but not limited to, use in life support applications, where malfunctions of product can cause injury to a person's health or life).

## Product qualification specifications

Characteristics			
External visual inspection	IPC-A-610		
Temperature shock test (Temperature cycling)	IEC 60068-2-14 Na	Temperature range Number of cycles Dwell/transfer time	-40 to 125°C 700 15 min/0-1 min
Cold (in operation)	IEC 60068-2-1 Ad	Temperature T <sub>A</sub> Duration	-45°C 72 h
Damp heat	IEC 60068-2-67 Cy	Temperature Humidity Duration	85°C 85% RH 1000 hours
Dry heat	IEC 60068-2-2 Bd	Temperature Duration	125°C 1000 h
Electrostatic discharge susceptibility	IEC 61340-3-1, JESD 22-A114 IEC 61340-3-2, JESD 22-A115	Human body model (HBM) Machine Model (MM)	Class 2, 2000 V Class 3, 200 V
Immersion in cleaning sol- vents	IEC 60068-2-45 XA, method 2	Water Flux Cleaner Isopropyl alcohol	55°C 23°C 35°C
Mechanical shock	IEC 60068-2-27 Ea	Peak acceleration Duration	100 g 6 ms
Moisture reflow sensitivity	J-STD-020E	Level 1 (SnPb-eutectic) Level 3 (Pb Free)	225°C 245°C
Operational Life test Rapid Temp.	MIL-STD-202G, method 108A	Duration	1000 h
Robustness of terminations	IEC 60068-2-21 Test Ue1	Surface mount products	All leads
Solderability	IEC 60068-2-20 test Ta	Preconditioning Temperature, Pb-free	Steam ageing 245°C
Vibration, broad band ran- dom	IEC 60068-2-64 Fh, method 1	Frequency Spectral density Duration	10 to 500 Hz 0.07 g <sup>2</sup> /Hz 10 min in each direction

## TECHNICAL REFERENCE DOCUMENT: DESIGN & APPLICATION GUIDELINES

### OPERATING INFORMATION: COMMON FEATURES

The features listed in the following pages are common to DC/DC converters.

#### VCC

A separate 5V Vcc voltage needs to be applied to the module in order to power the controller and driver circuits.

#### Turn on and off input voltage

The product monitors the input voltage and will turn on and turn off at configured thresholds (see *Technical Specification: part 1 - Electrical Specification*). The turn-on input voltage threshold is set higher than the corresponding turn-off threshold. Hence, there is a hysteresis between turn-on and turn-off input voltage levels.

#### Input voltage transient

The end-user must secure that the transient voltage will not exceed the value stated in the Technical Specification under Absolute maximum ratings of each product. ETSI TR 100 283 examines the parameters of DC distribution networks and provides guidelines for controlling the transient and reduce its harmful effect.

#### Remote control (RC)

The products are fitted with a remote control function referenced to the ground (GND), with negative and positive logic options available. The RC function allows the product to be turned on/off by an external device like a semiconductor or mechanical switch. The RC pin has an internal pull up resistor.

The 5V Vcc auxiliary power, and Vin should be ready before the remote control pin is set enable.

The minimum allowed time from where Vcc is applied to when RC is activated is 50ms.

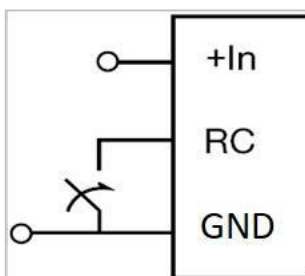

Remote control

The external device must provide a minimum required sink current  $>0.5$  mA to guarantee a voltage not higher than maximum voltage on the RC pin. Please refer to the Technical Specification/Electrical specifications of the product. When the RC pin is left open, the voltage on the RC pin is max 5 V. The standard product is provided with "positive logic" RC and will be off as long as the RC pin is connected to GND. To turn on the product the RC pin should be open.

## Input and output impedance

The impedance of both the input source and the load will interact with the impedance of the product. It is important that the input source has low characteristic impedance. Minimum recommended external input capacitance is given in the *Technical Specification*. Electrolytic capacitors will be degraded in low temperature. The needed input capacitance in low temperature should be equivalent to the value stated in the Technical Specification at 25°C. The performance in some applications can be enhanced by addition of external capacitance as described under External decoupling capacitors (next paragraph). If the input voltage source contains significant inductance, the addition of a low ESR ceramic capacitor of 22 – 100 µF capacitor across the input of the product will ensure stable operation. Input Voltage and output power changes the need of input capacitance whereas higher power requires increased input capacitance.

## External decoupling capacitors

Add low ESR ceramic and electrolytic capacitors as close to the load as possible, using several parallel capacitors is a good way to lower the effective ESR. The ceramic capacitors will handle high-frequency dynamic load changes while the electrolytic capacitors are used to handle low frequency dynamic load changes. It is equally important to use low resistance and low inductance PWB layouts and cabling.

For further information please contact your local Flex Power Modules' representative or email us at [pm.info@flex.com](mailto:pm.info@flex.com).

## Output voltage adjust and Margin using PMBus

As this device is unregulated no Output voltage adjust or Margin capabilities exists.

## Startup sequencing

This module can be started in two defined sequences.

1. Vcc is applied before Vin and finally the RC is activated.
2. Second sequency is to allow Vin applied before Vcc and finally activate the RC.

In both cases it is absolutely vital that the time from where Vcc is applied to when RC is activated is minimum 50ms.

This timing is very important in order to allow the controller to start the module in correct way.

Violating this requirement will result in catastrophic module failure.

## Soft start power up

The module has a built in soft start with a rise time of typically 10 ms. This is used to control inrush current.

The rise time is the time taken for the output to ramp to its target voltage. The soft start is not configurable.

## Pre-bias start-up

The product has a pre-bias start up functionality and will not sink current during start up if a pre-bias source is present at the output terminals. If the pre-bias voltage is lower than the output voltage, the product will ramp up to the target value.

## Over temperature protection (OTP)

The product is protected from thermal overload by an internal over temperature sensor. If the temperature exceeds the over-temperature threshold the module will shut down and enter latch mode.

The OTP warning, fault limit and fault response can be configured via the PMBus.

Note: using the fault response "ignore fault event" may cause permanent damage to the product.

## Input over/under voltage protection

The product can be protected from high input voltage and low input voltage by pre-configured values. The over/under-voltage fault level and fault response is easily configured via the PMBus.

For more information, see *Technical Reference Document: PMBus*.

## Output Over Voltage Protection (OVP)

The product includes over voltage limiting circuitry for protection of the load. If the output voltage exceeds the OVP limit, the product *can respond in different ways*.

The default response from an over voltage fault is to immediately shut down and enter latch mode.

OVP fault level and fault response can be configured via the PMBus.

For more information, see *Technical Reference Document: PMBus*.

## Over current protection (OCP)

The product includes current protection circuitry for output current overload.

For standard configuration the output current is measured through a difference in voltage across secondary FETs. If current exceeds max value the module will shut down and enter latch mode.

Over current protection can be configured via the PMBus.

For more information, see *Technical Reference Document: PMBus*.

A fast over current protection does also prevent fast current spikes on the output.

## Switching frequency

The product is optimized at the frequency given in the Technical Specification under part 1 - Electrical Specification. The frequency can not be changed by the user. Please contact your local Flex Power Modules FAE for more details.

## Address offset

It is possible to change the Address offset. Please contact your local Flex Power Modules FAE for more details.

## Output ripple and noise

Output ripple and noise measured according to figure below.  
See [Design Note 022](#) for detailed information.

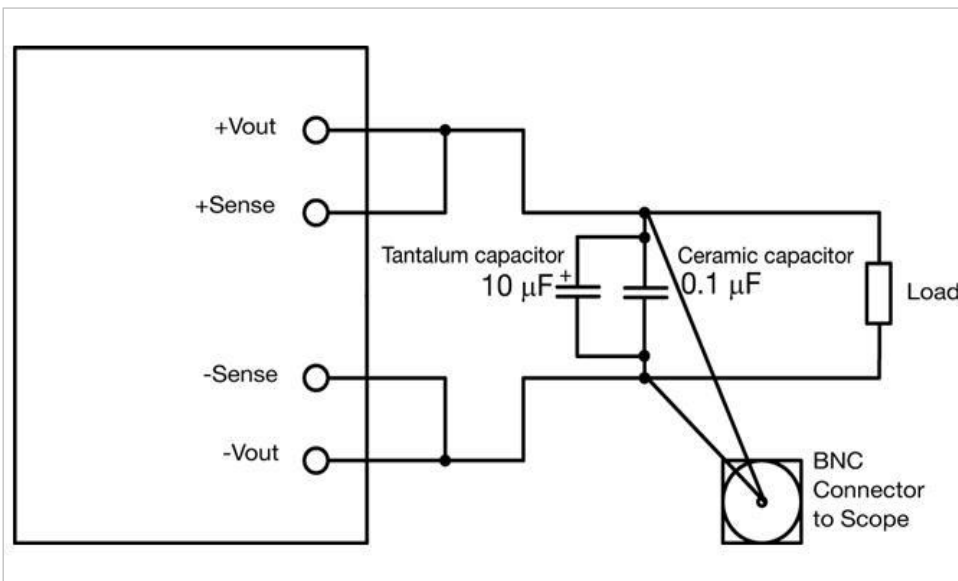

Output ripple and noise test set-up

## OPERATING INFORMATION: PRODUCT SPECIFIC FEATURES

### Parallel operation Droop Load Share (DLS)

Two or more products may be paralleled for redundancy. The products provide output voltage droop resistance in secondary transformer winding, which enables direct paralleling. The output voltage will decrease with increased load current. This feature allows the product to be connected in parallel and share current within 10% accuracy at max output power. This means that up to 90% of max rated current from each module can be utilized.

For further information please contact your local Flex Power Modules' representative or email us at [pm.info@flex.com](mailto:pm.info@flex.com).

## Power good

The power good pin (PG) indicates when the product is within the output voltage range. During ramp-up and any fault condition, PG is held low. By default PG is asserted high after the soft start is finished. The PG pin is configured as open drain and requires an external pull-up to Vcc.

The polarity is by default configured to active high.

When Vcc is first applied the module initialize the MCU and PG will be held low.

After input voltage is applied, the EN pin is set and the soft start sequence is initiated.

When the module completes its output ramp up and the output voltage is correct and stable, the PG signal will be set high.

Please refer to below sequence waveform.

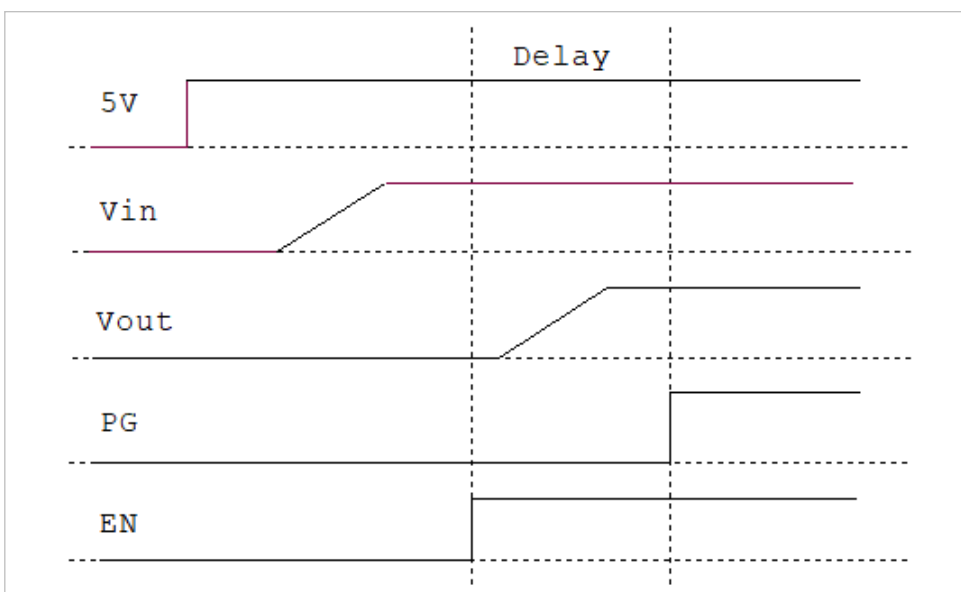

Power Good implementation

The product provides a Power Good flag in the Status Word register that indicates the output voltage is in correct level and no-fault condition.

For more information, see *Technical Reference Document: PMBus*.

## Non-Volatile Memory (NVM)

The product incorporates a Non-Volatile Memory implemented as with one-time programmable technology (OTP) for storage of the PMBus command values. Control registers are pre-loaded with Flex factory default values. The User may reprogram the user control registers through the PMBus Interface a limited amount of times.

For further information please contact your local Flex Power Modules' representative or email us at [pm.info@flex.com](mailto:pm.info@flex.com).

## POWER MANAGEMENT

### PMBUS overview

This product is equipped with a PMBus interface. The product incorporates a wide range of readable and configurable power management features that are simple to implement with a minimum of external components. Additionally, the product includes protection features that continuously safeguard the load from damage due to unexpected system faults. The following product parameters can continuously be monitored by a host: Input voltage, output voltage/current and internal temperature.

The product is delivered with a default configuration suitable for a wide range operation in terms of input voltage, output voltage, and load. The configuration is stored in an internal Non-Volatile Memory (NVM). Power management functions can be reconfigured using PMBus.

Throughout this document, different PMBus commands are referenced. The Flex Power Designer software suite can be used to configure and monitor this product via PMBus.

More information is found on [our website](#).

### SMBus interface

This product provides a PMBus digital interface that enables the user to configure many aspects of the device operation as well as to monitor the input and output voltages, output current and device temperature. The product can be used with any standard two-wire I<sup>2</sup>C (master must allow for clock stretching) or SMBus host device. In addition, the product is compatible with PMBus version 1.3. The product supports 100 kHz and 400 kHz bus clock frequency only. The PMBus signals, SCL and SDA require passive pull-up resistors as stated in the SMBus Specification. Pull-up resistors are required to guarantee the rise time as follows:

$$\tau = R_p C_p \leq 1\mu s$$

$R_p$  is the pull-up resistor value and  $C_p$  is the bus load. The maximum allowed bus load is 400 pF. The pull-up resistor should be tied to an external supply between 2.7 to 3.8 V, which should be present prior to or during power-up. If the proper power supply is not available, voltage dividers may be applied.

This module requires communication disabling PEC (Packet Error Check) when communicating via PMBus.

### PMBus addressing

The following figure and table show recommended resistor values with min and max range for hard-wiring PMBus addresses (series E96, 1% tolerance resistor suggested).

The SA pin can be configured with a resistor to GND according to the following table.

Address	Range of Rext [kOhm]		
	Min	Typ	Max
20h	0	0	0,147
21h	0,415	0,576	0,661
22h	0,956	1,05	1,168
23h	1,490	1,62	1,756
24h	2,110	2,26	2,500
25h	2,896	3,16	3,451
26h	3,900	4,22	4,704
27h	5,225	5,76	6,375
28h	6,996	7,68	8,647
29h	9,410	10,5	11,820
2Ah	12,793	14,3	16,328
2Bh	17,623	20	22,978
2Ch	24,800	28,4	34,840
2Dh	37,756	46,4	59,753
2Eh	65,633	86,6	118,984
2Fh	135,766	205	Open

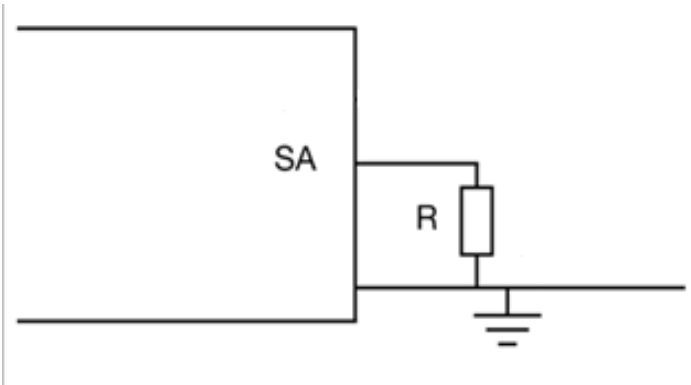

Schematic of connection address resistor

### I2C/SMBus timing

The setup time,  $t_{set}$ , is the time data, SDA, must be stable before the rising edge of the clock signal, SCL. The hold time  $t_{hold}$ , is the time data, SDA, must be stable after the rising edge of the clock signal, SCL. If these times are violated incorrect data may be captured or meta-stability may occur and the bus communication may fail. All standard SMBus protocols must be followed, including clock stretching. This product supports the BUSY flag in the status commands to indicate product being too busy for SMBus response. A bus-free time delay between every SMBus transmission (between every stop & start condition) must occur. Refer to the SMBus specification, for SMBus electrical and timing requirements.

Note that an additional delay of 300 ms has to be inserted in case of storing the RAM content into the internal non-volatile memory.

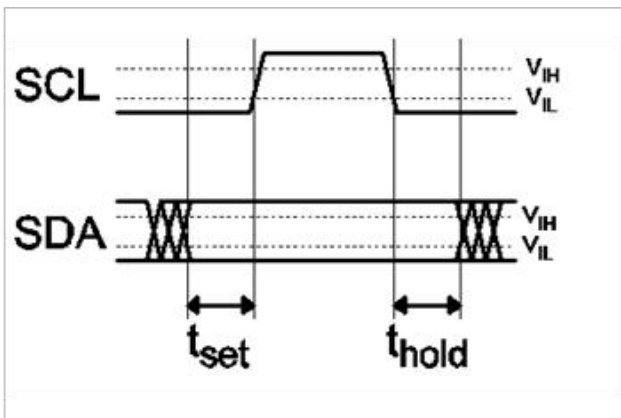

Set-up and hold timing diagramm

## Monitoring via PMBus

It is possible to continuously monitor a wide variety of parameters through the PMBus interface. These include, but are not limited to, the parameters listed in the table below.

Parameter	PMBus command
Input voltage	READ_VIN
Output voltage	READ_VOUT
Output current	READ_IOUT
Temperature*	READ_TEMPERATURE_1

\* reports the temperature from temperature sensor.

## Monitoring faults

It is possible to continuously monitor a wide variety of parameters through the PMBus interface. These include, but are not limited to, the parameters listed in the table below.

Fault and warning status	PMBus command
Overview, Power Good	STATUS_BYTE STATUS_WORD
Output voltage level	STATUS_VOUT
Output current level	STATUS_IOUT
Input voltage level	STATUS_INPUT
Temperature level	STATUS_TEMPERATURE
PMBus communication	STATUS_CML
Miscellaneous	STATUS_MFR_SPECIFIC

## General PMBus comand summary

PMBus signal interfaces characteristics

Characteristic	conditions	minimum	typical	maximum	unit
<b>PMBus signal interface characteristics</b>					
External sync pulse width		150			ns
Input clock frequency drift tolerance	External sync.	-4		4	%
Initialization time	From VI > 27 V to ready to be enabled		30		ms
Output voltage total on delay time	Enable by input voltage		$T_{INIT} + T_{ONdel}$		
	Enable by RC or CTRL pin		$T_{ONdel}$		
Logic output low signal level	SCL, DA, SYNC, GCB, SALERT, PG, sink/source current = 4 mA			0.25	V
Logic output high signal level		2.7			V
Logic output low sink current				4	mA
Logic output high source current				4	mA
Logic input low threshold	SCL, SDA, CTRL, SYNC			1.1	V
Logic input high threshold		2.1			V
Logic pin input capacitance	SCL, SDA, CTRL, SYNC		10		pF
Supported SMBus operating frequency		100		400	kHz
SMBus bus free time	STOP bit to START bit		1.3		μs
SMBus SDA setup time from SCL			100		μs
SMBus SDA hold time from SCL			0		ns
SMBus START/STOP condition setup/hold time from SCL			600		ns
SCL low period		1.3			μs
SCL high period			0.6	50	μs

## TECHNICAL REFERENCE DOCUMENT: SOLDERING

### Reflow soldering profile for surface mount

Products intended for surface mount assembly are qualified for use in a Pb-free forced convection or vapor phase reflow soldering process.

For Pb-free solder processes, a pin temperature ( $T_{pin}$ ) in excess of the solder melting temperature ( $T_L$ , 217 to 221°C for SnAgCu solder alloys) for more than 60 seconds and a peak temperature of 245°C on all pins is recommended to ensure a reliable solder joint.

$T_L$  is the typical solder melting (liquidous) temperature  
 $T_{product}$  is measured on the power module's hotspot  
 $T_{pin}$  is measured on the power module output power pins solder joints at the customer board

General reflow process specification		Pb-free, SAC305
Average ramp-up rate ( $T_{product}$ )		3 °C/s max
Typical solder melting temp.	$T_L$	217 °C
Min/Max. reflow time above $T_L$	$T_{pin}$	60 –150 s
Min. pin temp.	$T_{pin}$	235 °C
Peak product temp.	$T_{product}$	245 °C
Average ramp-down ( $T_{product}$ )		6°C/s max
Max. time 25° C to peak		8 minutes

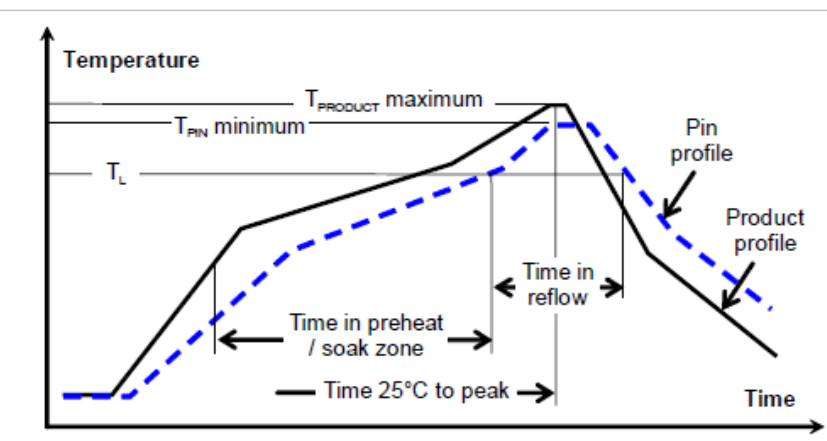

Typical soldering profile

## Moisture reflow classification

For Pb-free reflow solder processes, the product is qualified for MSL 3 according to IPC/JEDEC standard J-STD-020C.

## Dry pack information

Using products in high temperature reflow soldering processes requires dry pack storage and handling. Products intended for Pb-free reflow soldering processes are delivered in standard moisture barrier bags according to IPC/JEDEC standard J-STD-033 (handling, packing, shipping and use of moisture/reflow sensitivity surface mount devices). In case the products have been stored in an uncontrolled environment and no longer can be considered dry, floor life according to MSL 3, the modules must be baked according to J-STD-033.

## Post solder cleaning

A no-clean flux is recommended to avoid entrapment of cleaning fluids in cavities inside the product or between the product and the host board, since cleaning residues may affect long term reliability and isolation voltage.

## TECHNICAL REFERENCE DOCUMENT: SAFETY

### Safety specifications

Flex Power Modules' DC/DC converters and DC/DC regulators are designed in accordance with the safety standards *IEC 62368-1*, *EN 62368-1* and *UL 62368-1 Audio/video, information and communication technology equipment - Part 1: Safety requirements*

IEC/EN/UL 62368-1 contains requirements to prevent injury or damage due to the following hazards:

- Electrical shock
- Electrically-caused fire
- Injury caused by hazardous substances
- Mechanically-caused injury
- Skin burn
- Radiation-caused injury

On-board DC/DC converters, Power Interface Modules and DC/DC regulators are defined as component power supplies. As components they cannot fully comply with the provisions of any safety requirements without "conditions of acceptability". Clearance between conductors and between conductive parts of the component power supply and conductors on the board in the final product must meet the applicable safety requirements. Certain conditions of acceptability apply for component power supplies with limited stand-off (please refer to *Technical Specification under Mechanical Information* for further information). It is the responsibility of the installer to ensure that the final product housing these components complies with the requirements of all applicable safety standards and regulations for the final product.

Component power supplies for general use shall comply with the requirements in *IEC/EN/UL 62368-1*. Product related standards, e.g. *IEEE 802.3af Power over Ethernet*, and *ETS-300132-2 Power interface at the input to telecom equipment, operated by direct current (dc)* are based on *IEC/EN/UL 62368 -1* with regards to safety.

All Flex Power Modules' DC/DC converters, Power Interface Modules and DC/DC regulators are *UL 62368-1* recognized and certified in accordance with *EN 62368-1*. The flammability rating for all construction parts of the products meet requirements for V-0 class material according to *IEC 62368 -11-10*, Fire hazard testing, test flames – 50 W horizontal and vertical flame test methods.

## Technical Reference PMBus BMR320x000/001

This appendix contains a detailed reference of the PMBus commands supported by the product.

### Data Formats

The products make use of a few standardized numerical formats, along with custom data formats. A detailed walkthrough of the above formats is provided in AN304, as well as in sections 7 and 8 of the PMBus Specification Part II. The custom data formats vary depending on the command, and are detailed in the command description.

### Standard Commands

The functionality of commands with code 0x00 to 0xCF is usually based on the corresponding command specification provided in the PMBus Standard Specification Part II (see Power System Management Bus Protocol Documents below). However there might be different interpretations of the PMBus Standard Specification or only parts of the Standard Specification applied, thus the detailed command description below should always be consulted.

### Forum Websites

The System Management Interface Forum (SMIF)

<http://www.powersig.org/>

The System Management Interface Forum (SMIF) supports the rapid advancement of an efficient and compatible technology base that promotes power management and systems technology implementations. The SMIF provides a membership path for any company or individual to be active participants in any or all of the various working groups established by the implementer forums.

Power Management Bus Implementers Forum  
(PMBUS-IF)

<http://pmbus.org/>

The PMBus-IF supports the advancement and early adoption of the PMBus protocol for power management. This website offers recent PMBus specification documents, PMBus articles, as well as upcoming PMBus presentations and seminars, PMBus Document Review Board (DRB) meeting notes, and other PMBus related news.

### PMBus – Power System Management Bus Protocol Documents

These specification documents may be obtained from the PMBus-IF website described above. These are required reading for complete understanding of the PMBus implementation. This appendix will not re-address all of the details contained within the two PMBus Specification documents.

Specification Part I – General Requirements Transport And Electrical Interface

Includes the general requirements, defines the transport and electrical interface and timing requirements of hard wired signals.

Specification Part II – Command Language

Describes the operation of commands, data formats, fault management and defines the command language used with the PMBus.

### SMBus – System Management Bus Documents

System Management Bus Specification, Version 2.0, August 3, 2000

This specification specifies the version of the SMBus on which Revision 1.2 of the PMBus Specification is based. This specification is freely available from the System Management Interface Forum Web site at:

<http://www.smbus.org/specs/>

## PMBus Command Summary and Factory Default Values of Standard Configuration

The factory default values provided in the table below are valid for the Standard configuration. Factory default values for other configurations can be found using the Flex Power Designer tool.

Code	Name	Data Format	Factory Default Value Standard Configuration BMR320X000/001 R1	Min Set Value	Max Set Value	Unit	
0x00	PAGE	R/W Byte					
0x01	OPERATION	R/W Byte					
0x02	ON_OFF_CONFIG	R/W Byte	0x16				
0x03	CLEAR_FAULTS	Send Byte					
0x10	WRITE_PROTECT	R/W Byte	0x00				
0x19	CAPABILITY	Read Byte	0x20				
0x20	VOUT_MODE	Read Byte	0x1B				
0x35	VIN_ON	R/W Word	0xE928	37.00	30	50	V
0x40	VOUT_OV_FAULT_LIMIT	R/W Word	0x00FB	7.84	0	17	V
0x41	VOUT_OV_FAULT_RESPONSE	R/W Byte	0x80	0.00			ms
0x42	VOUT_OV_WARN_LIMIT	R/W Word	0x00F0	7.50	0	17	V
0x43	VOUT_UV_WARN_LIMIT	R/W Word	0x0090	4.50	0	15	V
0x44	VOUT_UV_FAULT_LIMIT	R/W Word	0x0080	4.00	0	15	V
0x45	VOUT_UV_FAULT_RESPONSE	R/W Byte	0x80	0.00			ms
0x46	IOUT_OC_FAULT_LIMIT	R/W Word	0xF168	90.00	0	240	A
0x47	IOUT_OC_FAULT_RESPONSE	R/W Byte	0xC0	0.00			ms
0x4A	IOUT_OC_WARN_LIMIT	R/W Word	0xF154	85.00	0	150	A
0x4F	OT_FAULT_LIMIT	R/W Word	0x007D	125.00	25	130	°C
0x50	OT_FAULT_RESPONSE	R/W Byte	0x80	0.00			ms
0x51	OT_WARN_LIMIT	R/W Word	0x0073	115.00	25	130	°C
0x55	VIN_OV_FAULT_LIMIT	R/W Word	0xEA00	64.00	0	68	V
0x56	VIN_OV_FAULT_RESPONSE	R/W Byte	0x80	0.00			ms
0x59	VIN_UV_FAULT_LIMIT	R/W Word	0xE91C	35.50	0	50	V
0x5A	VIN_UV_FAULT_RESPONSE	R/W Byte	0x80	0.00			ms
0x68	POUT_OP_FAULT_LIMIT	R/W Word	0x01FF	511.00	0	3000	W
0x69	POUT_OP_FAULT_RESPONSE	R/W Byte	0x00	0.00			ms
0x6A	POUT_OP_WARN_LIMIT	R/W Word	0x01FF	511.00	0	3000	W
0x78	STATUS_BYTE	Read Byte					
0x79	STATUS_WORD	Read Word					
0x7A	STATUS_VOUT	Read Byte					
0x7B	STATUS_IOUT	Read Byte					
0x7C	STATUS_INPUT	Read Byte					
0x7D	STATUS_TEMPERATURE	Read Byte					
0x7E	STATUS_CML	Read Byte					
0x80	STATUS_MFR_SPECIFIC	Read Byte					
0x88	READ_VIN	Read Word					
0x8B	READ_VOUT	Read Word					
0x8C	READ_IOUT	Read Word					
0x8D	READ_TEMPERATURE_1	Read Word					
0x96	READ_POUT	Read Word					
0x98	PMBUS_REVISION	Read Byte	0x33				
0x99	MFR_ID	Read Block2	0x001A				
0x9A	MFR_MODEL	Read Block2	0x6000				
0x9B	MFR_REVISION	Read Block2	0x0002				
0x9D	MFR_DATE	Read Block2	Unit Specific				

0xB0	MFR_SPEC_SERIAL	Read Block4	Unit Specific			
0xB1	MFR_SPEC_MODEL_REV	Read Block8	Unit Specific			
0xC4	PASSW_I2C	Write Word				
0xC5	PASSW_OTP	Write Word				
0xC6	PASSW_ADDR	Write Word				
0xCF	OTP_WRITE	Read Byte				
0xD3	DEVICE_FULL_ADDRESS	Read Byte				
0xD4	DCX_VOUT_SS_FAULT	R/W Byte	0x08			
0xD6	OTP_UPLOAD	R/W Byte				
0xD8	NTC_CS_LUT_STATUS	Read Byte	0x03			
0xDF	DCX_SS_PROTECTION	R/W Byte	0x15	2.50		ms
0xE0	PMBUS_BASE_ADDRESS	R/W Byte	0x44			
0xE1	NTC_LUT_CRC16_READ	Read Word				
0xE2	CS_LUT_CRC16_READ	Read Word				
0xEE	CHECKSUM_CRC	Read Word	Unit Specific			
0xF0	REG_CON_OFFSET_IOUT	R/W Byte	Unit Specific			
0xF1	REG_CON_MULT_IOUT	R/W Byte	Unit Specific			

**PMBus Command Details****PAGE (0x00)**

Description: Page command

Bit	Description	Format
7:0	Command for compability only, no function. Valid values are 0x00 and 0xFF.	Integer Unsigned

**OPERATION (0x01)**

Description: Sets the desired PMBus enable operation.

Bit	Description	Value	Function	Description
7:6	Make the device enable or disable if PMBus Enable has been activated in ON_OFF_CONFIG.	00	Immediate Off	Disable Immediately without sequencing.
		10	Enable	Enable device to the set voltage.

**ON\_OFF\_CONFIG (0x02)**

Description: Configures how the device is controlled by the EN pin and the PMBus OPERATION command. Setting bit 3 in ON\_OFF\_CONFIG to 1 will automatically set OPERATION = 0.

Bit	Function	Description	Value	Function	Description
4	Powerup Operation	Must be set to 1.	1	Enable pin or PMBus	Unit does not power up until commanded by the CONTROL pin and OPERATION command.
3	PMBus Enable Mode	Controls how the unit responds to commands received via the serial bus.	0	Ignore PMBus	Unit ignores the on/off portion of the OPERATION command from serial bus.
			1	Use PMBus	To start, the unit requires that the on/off portion of the OPERATION command is instructing the unit to run.
2	Enable Pin Mode	Controls how the unit responds to the CONTROL pin.	0	Ignore pin	Unit ignores the CONTROL/Enable pin.
			1	Use pin	Unit requires the CONTROL pin to be asserted to start the unit.
1	Enable Pin Polarity	Polarity of the CONTROL pin.	1	Active High	Enable pin will cause device to enable when driven high.
			0	Active Low	Enable pin will cause device to enable when driven low.
0	Disable Action	Must be set to 1.	1	Imm. Off	Turn off the output and stop transferring energy to the output as fast as possible.

**CLEAR\_FAULTS (0x03)**

Description: Clears all fault status bits

**WRITE\_PROTECT (0x10)**

Description: The WRITE\_PROTECT command is used to control writing to the PMBus device. The intent of this command is to provide protection against accidental changes. This command is not intended to provide protection against deliberate or malicious changes to a device's configuration or operation. Above what is specified in the PMBus standard the following protection modes are available: Data 0000 0011 =&gt; Disable all writes

Bit	Description	Value	Function	Description
7:0	All supported commands may have their parameters read, regardless of the WRITE_PROTECT settings.	0x80	Enable write command	Disable all writes except to the WRITE_PROTECT command.
		0x40	Enable operation	Disable all writes except to the WRITE_PROTECT, OPERATION and PAGE commands.
		0x20	Enable control and Vout commands	Disable all writes except to the WRITE_PROTECT, OPERATION, PAGE, ON_OFF_CONFIG and VOUT_COMMAND commands.
		0x03	Disable all writes	Disable all writes. Deadlock - needs a recycle of input voltage to unlock.
		0x02	Enable Vout command	Disable all writes except to the VOUT_COMMAND command. Deadlock - needs a recycle of input voltage to unlock.
		0x00	Enable all commands	Enable writes to all commands.

**CAPABILITY (0x19)**

Description: This command provides a way for a host system to determine some key capabilities of a PMBus device.

Bit	Function	Description	Value	Function	Description
7	Packet Error Checking	Packet error checking.	00	Not Supported	Packet Error Checking not supported.
			01	Supported	Packet Error Checking is supported.
6:5	Maximum Bus Speed	Maximum bus speed.	00	100kHz	Maximum supported bus speed is 100 kHz.
			01	400kHz	Maximum supported bus speed is 400 kHz.
			10	1MHz	Maximum supported bus speed is 1 MHz.
4	Smbalert	SMBALERT	00	No Smbalert	The device does not have a SMBALERT# pin and does not support the SMBus Alert Response protocol.
			01	Have Smbalert	The device does have a SMBALERT# pin and does support the SMBus Alert Response protocol.
3	Numeric Format	Numeric format.	0	LINEAR or DIRECT Format	Numeric data is in LINEAR or DIRECT format.
			1	IEEE Half Precision Floating Point Format	Numeric data is in IEEE half precision floating point format.
2	AVSBus Support	AVSBus support.	0	AVSBus Not Supported	AVSBus not supported.

			1	AVSBus Supported	AVSBus supported.
--	--	--	---	------------------	-------------------

**VOUT\_MODE (0x20)**

Description: Controls how future VOUT-related commands parameters will be interpreted.

Bit	Function	Description	Format
4:0		Five bit two's complement EXPONENT for the MANTISSA delivered as the data bytes for VOUT_COMMAND in VOUT_LINEAR Mode, five bit VID code identifier per in VID Mode or always set to 00000b in Direct Mode.	Integer Signed

Bit	Function	Description	Value	Function	Description
7:5		Set to 000b to select VOUT_LINEAR Mode (Five bit two's complement exponent for the MANTISSA delivered as the data bytes for an output voltage related command), set to 001b to select VID Mode (Five bit VID code identifier per) or set to 010b to select Direct Mode (Always set to 00000b).	000	Linear	Linear Mode Format.
			001	VID	VID Mode.
			010	Direct	Direct Mode.

**VIN\_ON (0x35)**

Description: The VIN\_ON command sets the value of the input voltage, in volts, at which the unit should start power conversion.

Bit	Description	Format	Unit
15:0	Sets the VIN ON threshold. Linear exponent must be set to -3.	Linear	V

**VOUT\_OV\_FAULT\_LIMIT (0x40)**

Description: Output over voltage fault limit. The actual level needed to trig a fault flag needs to be greater than the set level. This means the resolution will affect the exact trig level.

Bit	Description	Format	Unit
15:0	Output over voltage fault limit.	Vout Mode Unsigned (Exp = -5)	V

**VOUT\_OV\_FAULT\_RESPONSE (0x41)**

Description: Output over voltage fault response.

Bit	Function	Description	Format	Unit
2:0	Retry Time and Delay Time	Delay time in 200 ms units between attempts to restart.	Fixed Point Unsigned	ms

Bit	Function	Description	Value	Function	Description
7:6	Response		00	Ignore Fault	The PMBus device continues operation without interruption.

		Describes the device interruption operation. 00b - The PMBus device continues operation without interruption. 10b - The device shuts down (disables the output) and responds according to the Retry Setting in bits [5:3].	10	Disable and retry	The device shuts down (disables the output) and responds according to the retry setting in bits [5:3].
5:3	Retries	The device attempts to restart the number of times set by these bits. 000b means the device does not attempt a restart. 111b means the device attempts restarting continuously.	000	Do Not Retry	A zero value for the Retry Setting means that the unit does not attempt to restart. The output remains disabled until the fault is cleared (Section 10.7).
			001	Retry Once	The PMBus device attempts to restart 1 time. If the device fails to restart, it disables the output and remains off until the fault is cleared as described in Section 10.7. The time between the start of each attempt to restart is set by the value in bits [2:] along with the delay time unit specified for that particular fault.
			010	Retry Twice	The PMBus device attempts to restart 2 times. If the device fails to restart, it disables the output and remains off until the fault is cleared as described in Section 10.7. The time between the start of each attempt to restart is set by the value in bits [2:] along with the delay time unit specified for that particular fault.
			011	Retry 3 times	The PMBus device attempts to restart 3 times. If the device fails to restart, it disables the output and remains off until the fault is cleared as described in Section 10.7. The time between the start of each attempt to restart is set by the value in bits [2:] along with the delay time unit specified for that particular fault.

			100	Retry 4 times	The PMBus device attempts to restart 4 times. If the device fails to restart, it disables the output and remains off until the fault is cleared as described in Section 10.7. The time between the start of each attempt to restart is set by the value in bits [2:] along with the delay time unit specified for that particular fault.
			101	Retry 5 times	The PMBus device attempts to restart 5 times. If the device fails to restart, it disables the output and remains off until the fault is cleared as described in Section 10.7. The time between the start of each attempt to restart is set by the value in bits [2:] along with the delay time unit specified for that particular fault.
			110	Retry 6 times	The PMBus device attempts to restart 6 times. If the device fails to restart, it disables the output and remains off until the fault is cleared as described in Section 10.7. The time between the start of each attempt to restart is set by the value in bits [2:] along with the delay time unit specified for that particular fault.
			111	Retry Continuously	The PMBus device attempts to restart continuously, without limitation, until it is commanded OFF (by the CONTROL pin or OPERATION command or both), bias power is removed, or another fault condition causes the unit to shut down.

**VOUT\_OV\_WARN\_LIMIT (0x42)**

Description: Output over voltage warning limit.

Bit	Description	Format	Unit
15:0	Output over voltage warning limit.	Vout Mode Unsigned (Exp = -5)	V

**VOUT\_UV\_WARN\_LIMIT (0x43)**

Description: Output under voltage warning limit.

Bit	Description	Format	Unit
15:0	Output under voltage warning limit.	Vout Mode Unsigned (Exp = -5)	V

**VOUT\_UV\_FAULT\_LIMIT (0x44)**

Description: Output under voltage fault limit.

Bit	Description	Format	Unit
15:0	Output under voltage fault limit.	Vout Mode Unsigned (Exp = -5)	V

**VOUT\_UV\_FAULT\_RESPONSE (0x45)**

Description: Output under voltage fault response.

Bit	Function	Description	Format	Unit
2:0	Retry Time and Delay Time	Delay time in 200 ms units between attempts to restart.	Fixed Point Unsigned	ms

Bit	Function	Description	Value	Function	Description
7:6	Response	Describes the device interruption operation. 00b - The PMBus device continues operation without interruption. 10b - The device shuts down (disables the output) and responds according to the Retry Setting in bits [5:3].	00	Ignore Fault	The PMBus device continues operation without interruption.
			10	Disable and retry	The device shuts down (disables the output) and responds according to the retry setting in bits [5:3].
5:3	Retries	The device attempts to restart the number of times set by these bits. 000b means the device does not attempt a restart. 111b means the device attempts restarting continuously.	000	Do Not Retry	A zero value for the Retry Setting means that the unit does not attempt to restart. The output remains disabled until the fault is cleared (Section 10.7).
			001	Retry Once	The PMBus device attempts to restart 1 time. If the device fails to restart, it disables the output and remains off until the fault is cleared as described in Section 10.7. The time between the start of each attempt to restart is set by the value in bits [2:] along with the delay time unit specified for that particular fault.

			010	Retry Twice	The PMBus device attempts to restart 2 times. If the device fails to restart, it disables the output and remains off until the fault is cleared as described in Section 10.7. The time between the start of each attempt to restart is set by the value in bits [2:] along with the delay time unit specified for that particular fault.
			011	Retry 3 times	The PMBus device attempts to restart 3 times. If the device fails to restart, it disables the output and remains off until the fault is cleared as described in Section 10.7. The time between the start of each attempt to restart is set by the value in bits [2:] along with the delay time unit specified for that particular fault.
			100	Retry 4 times	The PMBus device attempts to restart 4 times. If the device fails to restart, it disables the output and remains off until the fault is cleared as described in Section 10.7. The time between the start of each attempt to restart is set by the value in bits [2:] along with the delay time unit specified for that particular fault.
			101	Retry 5 times	The PMBus device attempts to restart 5 times. If the device fails to restart, it disables the output and remains off until the fault is cleared as described in Section 10.7. The time between the start of each attempt to restart is set by the value in bits [2:] along with the delay time unit specified for that particular fault.

			110	Retry 6 times	The PMBus device attempts to restart 6 times. If the device fails to restart, it disables the output and remains off until the fault is cleared as described in Section 10.7. The time between the start of each attempt to restart is set by the value in bits [2:] along with the delay time unit specified for that particular fault.
			111	Retry Continuously	The PMBus device attempts to restart continuously, without limitation, until it is commanded OFF (by the CONTROL pin or OPERATION command or both), bias power is removed, or another fault condition causes the unit to shut down.

**IOUT\_OC\_FAULT\_LIMIT (0x46)**

Description: Output over current limit. The actual level needed to trig a fault flag needs to be greater than the set level. This means the resolution will affect the exact trig level.

Bit	Description	Format	Unit
15:0	Output over current fault limit. Linear exponent must be -2.	Linear	A

**IOUT\_OC\_FAULT\_RESPONSE (0x47)**

Description: Output over current fault response.

Bit	Function	Description	Format	Unit
2:0	Retry Time and Delay Time	Delay time in 200 ms units between attempts to restart.	Fixed Point Unsigned	ms

Bit	Function	Description	Value	Function	Description
7:6	Response	For all values of bits [7:6], the device: Sets the corresponding fault bit in the status registers and If the device supports notifying the host, it does so.	00	Ignore Fault	The PMBus device continues to operate indefinitely while maintaining the output current at the value set by IOUT_OC_FAULT_LIMIT without regard to the output voltage (known as constant-current or brickwall limiting).
			11	Disable and Retry	The device shuts down (disables the output) and responds according to the retry setting in bits [5:3].
5:3	Retries		000	Do Not Retry	A zero value for the Retry Setting means that the unit does not attempt to restart. The output remains disabled until the fault is cleared (Section 10.7).

		The device attempts to restart the number of times set by these bits. 000b means the device does not attempt a restart. 111b means the device attempts restarting continuously.	001	Retry Once	The PMBus device attempts to restart 1 time. If the device fails to restart, it disables the output and remains off until the fault is cleared as described in Section 10.7. The time between the start of each attempt to restart is set by the value in bits [2:] along with the delay time unit specified for that particular fault.
			010	Retry Twice	The PMBus device attempts to restart 2 times. If the device fails to restart, it disables the output and remains off until the fault is cleared as described in Section 10.7. The time between the start of each attempt to restart is set by the value in bits [2:] along with the delay time unit specified for that particular fault.
			011	Retry 3 times	The PMBus device attempts to restart 3 times. If the device fails to restart, it disables the output and remains off until the fault is cleared as described in Section 10.7. The time between the start of each attempt to restart is set by the value in bits [2:] along with the delay time unit specified for that particular fault.
			100	Retry 4 times	The PMBus device attempts to restart 4 times. If the device fails to restart, it disables the output and remains off until the fault is cleared as described in Section 10.7. The time between the start of each attempt to restart is set by the value in bits [2:] along with the delay time unit specified for that particular fault.

			101	Retry 5 times	The PMBus device attempts to restart 5 times. If the device fails to restart, it disables the output and remains off until the fault is cleared as described in Section 10.7. The time between the start of each attempt to restart is set by the value in bits [2:] along with the delay time unit specified for that particular fault.
			110	Retry 6 times	The PMBus device attempts to restart 6 times. If the device fails to restart, it disables the output and remains off until the fault is cleared as described in Section 10.7. The time between the start of each attempt to restart is set by the value in bits [2:] along with the delay time unit specified for that particular fault.
			111	Retry Continuously	The PMBus device attempts to restart continuously, without limitation, until it is commanded OFF (by the CONTROL pin or OPERATION command or both), bias power is removed, or another fault condition causes the unit to shut down.

**IOUT\_OC\_WARN\_LIMIT (0x4A)**

Description: Output over current warning limit. The actual level needed to trig a fault flag needs to be greater than the set level. This means the resolution will affect the exact trig level.

Bit	Description	Format	Unit
15:0	Output over current warning limit. Linear exponent must be set to -2.	Linear	A

**OT\_FAULT\_LIMIT (0x4F)**

Description: Over temperature fault limit. The actual level needed to trig a fault flag needs to be greater than the set level. This means the resolution will affect the exact trig level.

Bit	Description	Format	Unit
15:0	Over temperature fault limit. Linear exponent must be set to 0.	Linear	°C

**OT\_FAULT\_RESPONSE (0x50)**

Description: Over temperature fault response.

Bit	Function	Description	Format	Unit
2:0	Retry Time and Delay Time	Delay time in 200 ms units between attempts to restart.	Fixed Point Unsigned	ms

Bit	Function	Description	Value	Function	Description
7:6	Response		00	Ignore Fault	The PMBus device continues operation without interruption.
			10	Disable and retry	The device shuts down (disables the output) and responds according to the retry setting in bits [5:3].
5:3	Retries		000	Do Not Retry	A zero value for the Retry Setting means that the unit does not attempt to restart. The output remains disabled until the fault is cleared (Section 10.7).
			001	Retry Once	The PMBus device attempts to restart 1 time. If the device fails to restart, it disables the output and remains off until the fault is cleared as described in Section 10.7. The time between the start of each attempt to restart is set by the value in bits [2:] along with the delay time unit specified for that particular fault.
			010	Retry Twice	The PMBus device attempts to restart 2 times. If the device fails to restart, it disables the output and remains off until the fault is cleared as described in Section 10.7. The time between the start of each attempt to restart is set by the value in bits [2:] along with the delay time unit specified for that particular fault.
			011	Retry 3 times	The PMBus device attempts to restart 3 times. If the device fails to restart, it disables the output and remains off until the fault is cleared as described in Section 10.7. The time between the start of each attempt to restart is set by the value in bits [2:] along with the delay time unit specified for that particular fault.

			100	Retry 4 times	The PMBus device attempts to restart 4 times. If the device fails to restart, it disables the output and remains off until the fault is cleared as described in Section 10.7. The time between the start of each attempt to restart is set by the value in bits [2:] along with the delay time unit specified for that particular fault.
			101	Retry 5 times	The PMBus device attempts to restart 5 times. If the device fails to restart, it disables the output and remains off until the fault is cleared as described in Section 10.7. The time between the start of each attempt to restart is set by the value in bits [2:] along with the delay time unit specified for that particular fault.
			110	Retry 6 times	The PMBus device attempts to restart 6 times. If the device fails to restart, it disables the output and remains off until the fault is cleared as described in Section 10.7. The time between the start of each attempt to restart is set by the value in bits [2:] along with the delay time unit specified for that particular fault.
			111	Retry Continuously	The PMBus device attempts to restart continuously, without limitation, until it is commanded OFF (by the CONTROL pin or OPERATION command or both), bias power is removed, or another fault condition causes the unit to shut down.

**OT\_WARN\_LIMIT (0x51)**

Description: Over temperature warning limit. The actual level needed to trig a fault flag needs to be greater than the set level. This means the resolution will affect the exact trig level.

Bit	Description	Format	Unit
15:0	Over temperature warning limit. Linear exponent must be set to 0.	Linear	°C

**VIN\_OV\_FAULT\_LIMIT (0x55)**

Description: Input over voltage fault limit. The input status register is not updated when the unit is in standby mode (not enabled). This means that an input over-voltage is detected just after the unit starts to ramp and consequently shut down again. The actual level needed to trig a fault flag needs to be greater than the set level. This means the resolution will affect the exact trig level.

Bit	Description	Format	Unit
15:0	Input over voltage fault limit. Linear exponent must be set to -3.	Linear	V

**VIN\_OV\_FAULT\_RESPONSE (0x56)**

Description: Input over voltage fault response.

Bit	Function	Description	Format	Unit
2:0	Retry Time and Delay Time	Delay time in 200 ms units between attempts to restart.	Fixed Point Unsigned	ms

Bit	Function	Description	Value	Function	Description
7:6	Response		00	Ignore Fault	The PMBus device continues operation without interruption.
			10	Disable and retry	The device shuts down (disables the output) and responds according to the retry setting in bits [5:3].
5:3	Retries		000	Do Not Retry	A zero value for the Retry Setting means that the unit does not attempt to restart. The output remains disabled until the fault is cleared (Section 10.7).
			001	Retry Once	The PMBus device attempts to restart 1 time. If the device fails to restart, it disables the output and remains off until the fault is cleared as described in Section 10.7. The time between the start of each attempt to restart is set by the value in bits [2:] along with the delay time unit specified for that particular fault.
			010	Retry Twice	The PMBus device attempts to restart 2 times. If the device fails to restart, it disables the output and remains off until the fault is cleared as described in Section 10.7. The time between the start of each attempt to restart is set by the value in bits [2:] along with the delay time unit specified for that particular fault.

			011	Retry 3 times	The PMBus device attempts to restart 3 times. If the device fails to restart, it disables the output and remains off until the fault is cleared as described in Section 10.7. The time between the start of each attempt to restart is set by the value in bits [2:] along with the delay time unit specified for that particular fault.
			100	Retry 4 times	The PMBus device attempts to restart 4 times. If the device fails to restart, it disables the output and remains off until the fault is cleared as described in Section 10.7. The time between the start of each attempt to restart is set by the value in bits [2:] along with the delay time unit specified for that particular fault.
			101	Retry 5 times	The PMBus device attempts to restart 5 times. If the device fails to restart, it disables the output and remains off until the fault is cleared as described in Section 10.7. The time between the start of each attempt to restart is set by the value in bits [2:] along with the delay time unit specified for that particular fault.
			110	Retry 6 times	The PMBus device attempts to restart 6 times. If the device fails to restart, it disables the output and remains off until the fault is cleared as described in Section 10.7. The time between the start of each attempt to restart is set by the value in bits [2:] along with the delay time unit specified for that particular fault.
			111	Retry Continuously	The PMBus device attempts to restart continuously, without limitation, until it is commanded OFF (by the CONTROL pin or OPERATION command or both), bias power is removed, or another fault condition causes the unit to shut down.

**VIN\_UV\_FAULT\_LIMIT (0x59)**

Description: Input under voltage fault limit.

Bit	Description	Format	Unit
15:0	Input under voltage fault limit. Linear exponent must be set to -3.	Linear	V

**VIN\_UV\_FAULT\_RESPONSE (0x5A)**

Description: Input under voltage fault response.

Bit	Function	Description	Format	Unit
2:0	Retry Time and Delay Time	Delay time in 200 ms units between attempts to restart.	Fixed Point Unsigned	ms

Bit	Function	Description	Value	Function	Description
7:6	Response		00	Ignore Fault	The PMBus device continues operation without interruption.
			10	Disable and retry	The device shuts down (disables the output) and responds according to the retry setting in bits [5:3].
5:3	Retries		000	Do Not Retry	A zero value for the Retry Setting means that the unit does not attempt to restart. The output remains disabled until the fault is cleared (Section 10.7).
			001	Retry Once	The PMBus device attempts to restart 1 time. If the device fails to restart, it disables the output and remains off until the fault is cleared as described in Section 10.7. The time between the start of each attempt to restart is set by the value in bits [2:] along with the delay time unit specified for that particular fault.
			010	Retry Twice	The PMBus device attempts to restart 2 times. If the device fails to restart, it disables the output and remains off until the fault is cleared as described in Section 10.7. The time between the start of each attempt to restart is set by the value in bits [2:] along with the delay time unit specified for that particular fault.

			011	Retry 3 times	The PMBus device attempts to restart 3 times. If the device fails to restart, it disables the output and remains off until the fault is cleared as described in Section 10.7. The time between the start of each attempt to restart is set by the value in bits [2:] along with the delay time unit specified for that particular fault.
			100	Retry 4 times	The PMBus device attempts to restart 4 times. If the device fails to restart, it disables the output and remains off until the fault is cleared as described in Section 10.7. The time between the start of each attempt to restart is set by the value in bits [2:] along with the delay time unit specified for that particular fault.
			101	Retry 5 times	The PMBus device attempts to restart 5 times. If the device fails to restart, it disables the output and remains off until the fault is cleared as described in Section 10.7. The time between the start of each attempt to restart is set by the value in bits [2:] along with the delay time unit specified for that particular fault.
			110	Retry 6 times	The PMBus device attempts to restart 6 times. If the device fails to restart, it disables the output and remains off until the fault is cleared as described in Section 10.7. The time between the start of each attempt to restart is set by the value in bits [2:] along with the delay time unit specified for that particular fault.
			111	Retry Continuously	The PMBus device attempts to restart continuously, without limitation, until it is commanded OFF (by the CONTROL pin or OPERATION command or both), bias power is removed, or another fault condition causes the unit to shut down.

**POUT\_OP\_FAULT\_LIMIT (0x68)**

Description: Sets the Output power over-power fault limit. The actual level needed to trig a fault flag needs to be greater than the set level. This means the resolution will affect the exact trig level.

Bit	Description	Format	Unit
15:0	Output power over-power fault limit. Linear exponent must be set to 3.	Linear	W

**POUT\_OP\_FAULT\_RESPONSE (0x69)**

Description: Sets the output power Over-Power fault response.

Bit	Function	Description	Format	Unit
2:0	Retry Time and Delay Time	Delay time in 200 ms units between attempts to restart.	Fixed Point Unsigned	ms

Bit	Function	Description	Value	Function	Description
7:6	Response		00	Ignore Fault	The PMBus device continues operation without interruption.
			10	Disable and retry	The device shuts down (disables the output) and responds according to the retry setting in bits [5:3].
5:3	Retries		000	Do Not Retry	A zero value for the Retry Setting means that the unit does not attempt to restart. The output remains disabled until the fault is cleared (Section 10.7).
			001	Retry Once	The PMBus device attempts to restart 1 time. If the device fails to restart, it disables the output and remains off until the fault is cleared as described in Section 10.7. The time between the start of each attempt to restart is set by the value in bits [2:] along with the delay time unit specified for that particular fault.
			010	Retry Twice	The PMBus device attempts to restart 2 times. If the device fails to restart, it disables the output and remains off until the fault is cleared as described in Section 10.7. The time between the start of each attempt to restart is set by the value in bits [2:] along with the delay time unit specified for that particular fault.

			011	Retry 3 times	The PMBus device attempts to restart 3 times. If the device fails to restart, it disables the output and remains off until the fault is cleared as described in Section 10.7. The time between the start of each attempt to restart is set by the value in bits [2:] along with the delay time unit specified for that particular fault.
			100	Retry 4 times	The PMBus device attempts to restart 4 times. If the device fails to restart, it disables the output and remains off until the fault is cleared as described in Section 10.7. The time between the start of each attempt to restart is set by the value in bits [2:] along with the delay time unit specified for that particular fault.
			101	Retry 5 times	The PMBus device attempts to restart 5 times. If the device fails to restart, it disables the output and remains off until the fault is cleared as described in Section 10.7. The time between the start of each attempt to restart is set by the value in bits [2:] along with the delay time unit specified for that particular fault.
			110	Retry 6 times	The PMBus device attempts to restart 6 times. If the device fails to restart, it disables the output and remains off until the fault is cleared as described in Section 10.7. The time between the start of each attempt to restart is set by the value in bits [2:] along with the delay time unit specified for that particular fault.
			111	Retry Continuously	The PMBus device attempts to restart continuously, without limitation, until it is commanded OFF (by the CONTROL pin or OPERATION command or both), bias power is removed, or another fault condition causes the unit to shut down.

**POUT\_OP\_WARN\_LIMIT (0x6A)**

Description: Sets the Output power over-power warn limit. The actual level needed to trig a fault flag needs to be greater than the set level. This means the resolution will affect the exact trig level.

Bit	Description	Format	Unit
15:0	Output power over-power warn limit. Linear exponent must be set to 3.	Linear	W

**STATUS\_BYTE (0x78)**

Description: Returns a brief fault/warning status byte. Status flags are not cleared after enable on/off as described in PMBus 1.4 §10.2.3.

Bit	Function	Description	Value	Description
6	Off	This bit is asserted if the unit is not providing power to the output, regardless of the reason, including simply not being enabled.	0	No fault
			1	Fault
5	Vout Overvoltage Fault	An output overvoltage fault has occurred.	0	No fault
			1	Fault
4	Iout Overcurrent Fault	An output overcurrent fault has occurred.	0	No fault
			1	Fault
3	Vin Undervoltage Fault	An input undervoltage fault has occurred.	0	No fault
			1	Fault
2	Temperature	A temperature fault or warning has occurred.	0	No fault
			1	Fault
1	Communication/Logic	A communications, memory or logic fault has occurred.	0	No fault
			1	Fault
0	None of the Above	A fault or warning not listed in bits [7:1] has occurred.	0	No fault
			1	Fault

**STATUS\_WORD (0x79)**

Description: Returns an extended fault/warning status byte. Status flags are not cleared after enable on/off as described in PMBus 1.4 §10.2.3.

Bit	Function	Description	Value	Description
15	Vout	An output voltage fault or warning has occurred.	0	No fault
			1	Fault
14	Iout/Pout	An output current or output power fault or warning has occurred.	0	No Fault.
			1	Fault.
13	Input	An input voltage, input current, or input power fault or warning has occurred.	0	No Fault.
			1	Fault.
12	Mfr Specific	A manufacturer specific fault or warning has occurred.	0	No Fault.
			1	Fault.
11	Power-Good	The Power-Good signal, if present, is negated.	0	No Fault.
			1	Fault.
6	Off	This bit is asserted if the unit is not providing power to the output, regardless of the reason, including simply not being enabled.	0	No fault
			1	Fault
5	Vout Overvoltage Fault	An output overvoltage fault has occurred.	0	No Fault.
			1	Fault.
4	Iout Overcurrent Fault	An output overcurrent fault has occurred.	0	No Fault.
			1	Fault.
3	Vin Undervoltage Fault	An input undervoltage fault has occurred.	0	No Fault.
			1	Fault.
2	Temperature	A temperature fault or warning has occurred.	0	No Fault.
			1	Fault.

1	Communication/Logic	A communications, memory or logic fault has occurred.	0	No fault.
			1	Fault.
0	None of the Above	A fault or warning not listed in bits [7:1] has occurred.	0	No fault.
			1	Fault.

**STATUS\_VOUT (0x7A)**

Description: Returns Vout-related fault/warning status bits. Status flags are not cleared after enable on/off as described in PMBus 1.4 §10.2.3.

Bit	Function	Description	Value	Description
7	Vout Overvoltage Fault	Vout Overvoltage Fault.	0	No Fault.
			1	Fault.
6	Vout Overvoltage Warning	Vout Overvoltage Warning.	0	No Warning.
			1	Warning.
5	Vout Undervoltage Warning	Vout Undervoltage Warning.	0	No Warning.
			1	Warning.
4	Vout Undervoltage Fault	Vout Undervoltage Fault.	0	No Fault.
			1	Fault.

**STATUS\_IOUT (0x7B)**

Description: Returns Iout-related fault/warning status bits. Status flags are not cleared after enable on/off as described in PMBus 1.4 §10.2.3.

Bit	Function	Description	Value	Description
7	Iout Overcurrent Fault	Iout Overcurrent Fault.	0	No Fault.
			1	Fault.
5	Iout Over Current Warning	Iout Overcurrent Warning.	0	No Warning.
			1	Warning.
1	Pout Over Power Fault	Pout Over Power Fault.	0	No Fault.
			1	Fault.
0	Pout Over Power Warning	Pout Over Power Warning.	0	No Warning.
			1	Warning.

**STATUS\_INPUT (0x7C)**

Description: Returns VIN/IIN-related fault/warning status bits. Status flags are not cleared after enable on/off as described in PMBus 1.4 §10.2.3.

Bit	Function	Description	Value	Description
7	Vin Overvoltage Fault	Vin Overvoltage Fault.	0	No Fault.
			1	Fault.
6	Vin Overvoltage Warning	VIN Overvoltage Warning.	0	No Warning.
			1	Warning.
5	Vin Undervoltage Warning	Vin Undervoltage Warning.	0	No Warning.
			1	Warning.
4	Vin Undervoltage Fault	Vin Undervoltage Fault.	0	No Fault.
			1	Fault.
3	Insufficient Vin	Asserted when either the input voltage has never exceeded the input turn-on threshold Vin-On, or if the unit did start, the input voltage decreased below the turn-off threshold.	0	No Insufficient VIN encountered yet.
			1	Insufficient Unit is off.

**STATUS\_TEMPERATURE (0x7D)**

Description: Returns the temperature-related fault/warning status bits. Status flags are not cleared after enable on/off as described in PMBus 1.4 §10.2.3.

Bit	Function	Description	Value	Description
7	Overtemperature Fault	Overtemperature Fault.	0	No Fault.
			1	Fault.
6	Overtemperature Warning	Overtemperature Warning.	0	No Warning.
			1	Warning.

**STATUS\_CML (0x7E)**

Description: Returns Communication/Logic/Memory-related fault/warning status bits. Status flags are not cleared after enable on/off as described in PMBus 1.4 §10.2.3.

Bit	Function	Description	Value	Description
7	Invalid or Unsupported Command Received	Invalid or Unsupported Command Received.	0	No Invalid Command Received.
			1	Invalid Command Received.
6	Invalid or Unsupported Data Received	Invalid or Unsupported Data Received.	0	No Invalid Data Received.
			1	Invalid Data Received.
5	Packet Error Check Failed	Packet Error Check Failed.	0	No Failure.
			1	Failure.
4	Memory Fault Detected	Memory Fault Detected.	0	No Fault.
			1	Fault.

**STATUS\_MFR\_SPECIFIC (0x80)**

Description: Returns manufacturer specific status information. Status flags are not cleared after enable on/off as described in PMBus 1.4 §10.2.3.

Bit	Function	Description	Value	Description
7	Analog Ratio Protection	Analog Ratio Protection.	0	No Fault.
			1	Fault.
6	Digital Ratio Protection	Digital Ratio Protection; $N * V_{out} - V_{INSS}$ .	0	No Fault.
			1	Fault.
5	Buck Duty Fault	Buck duty fault; $ V_{BUS} - V_{INSS}  < K * V_{INSS}$ .	0	No Fault.
			1	Fault.
4	Analog (peak) OC Protection	Analog (peak) OC protection.	0	No Fault.
			1	Fault.
2	Vout Monotonic Rise Fault	Vout rise is not monotonic at startup, i.e. short circuit on output.	0	No Fault.
			1	Fault.
1	VCC Boot Below Threshold	At the start-up, the VCC was below threshold.	0	No Fault.
			1	Fault.
0	Vout Boot Below Threshold	At the start-up, the VOUT was below threshold.	0	No Fault.
			1	Fault.

**READ\_VIN (0x88)**

Description: Returns the measured input voltage.

Bit	Description	Format	Unit
15:0	Returns the input voltage reading.	Linear	V

**READ\_VOUT (0x8B)**

Description: Returns the measured output voltage.

Bit	Description	Format	Unit
-----	-------------	--------	------

15:0	Returns the measured output voltage.	Vout Mode Unsigned (Exp = -5)	V
------	--------------------------------------	-------------------------------	---

**READ\_IOUT (0x8C)**

Description: Returns the measured output current.

Bit	Description	Format	Unit
15:0	Returns the measured output current.	Linear	A

**READ\_TEMPERATURE\_1 (0x8D)**

Description: Reads temperature from the internal sensor.

Bit	Description	Format	Unit
15:0		Linear	°C

**READ\_POUT (0x96)**

Description: Returns the calculated output power.

Bit	Description	Format	Unit
15:0		Linear	W

**PMBUS\_REVISION (0x98)**

Description: Returns the PMBus revision number for this device.

Bit	Function	Description	Value	Function	Description
7:4	Part I Revision	Part I Revision.	0x0	1.0	Part I Revision 1.0.
			0x1	1.1	Part I Revision 1.1.
			0x2	1.2	Part I Revision 1.2.
			0x3	1.3	Part I Revision 1.3.
3:0	Part II Revision	Part II Revision.	0x0	1.0	Part II Revision 1.0.
			0x1	1.1	Part II Revision 1.1.
			0x2	1.2	Part II Revision 1.2.
			0x3	1.3	Part II Revision 1.3.

**MFR\_ID (0x99)**

Description: Sets the Manufacturers ID

Bit	Description	Format
15:0	Manufacturer ID.	Integer Unsigned

**MFR\_MODEL (0x9A)**

Description: Mfr. Model

Bit	Description	Format
15:0	Mfr. Model.	ASCII

**MFR\_REVISION (0x9B)**

Description: Sets the MFR revision string.

Bit	Description	Format
15:0	Mfr. Revision.	Integer Unsigned

**MFR\_DATE (0x9D)**

Description: This command returns the date the regulator was manufactured.

Bit	Function	Description	Format
15:8	Mfr. Week	The week number.	Integer Unsigned
7:0	Mfr. Year	The year (e.g. 20 stands for 2020).	Integer Unsigned

**MFR\_SPEC\_SERIAL (0xB0)**

Description: Contains serial # from production.

Bit	Function	Description	Format
31:27	Test station number	Test station number, e.g. 00000 = X01	Integer Unsigned
26:0	Serial number	Serial number. Decimal number calculated as: 100000 x (Last three digits of production order number) + counter number	Integer Unsigned

**MFR\_SPEC\_MODEL\_REV (0xB1)**

Description: Contains product number and revision information.

Bit	Function	Description	Format
63	Scheme ID	Always 1	Integer Unsigned
59:50	BMR number 3-digit	Number 001-999.	Integer Unsigned
49:46	BMR number 1-digit	Number 0-9.	Integer Unsigned
45:42	BMR number 1-digit	Number 0-9.	Integer Unsigned
41:38	BMR number 1-digit	Number 0-9.	Integer Unsigned
37:34	BMR number 1-digit	Number 0-9.	Integer Unsigned
33:24	BMR number after /	Number 001-999.	Integer Unsigned
22:17	Product revision number	Number 1-63.	Integer Unsigned
16:12	Product revision letter	Number 1-26 represents A-Z.	Integer Unsigned
10:6	Config revision letter	Number 1-26 represents A-Z.	Integer Unsigned
5:0	Config revision number	Number 1-63. Ignore for sharp release.	Integer Unsigned

Bit	Function	Description	Value	Description
23	Product preliminary revision	0=Sharp revision (e.g. R1A), 1=Preliminary revision (e.g. P1A)	0	Sharp revision (e.g. R1A)
			1	Preliminary revision (e.g. P1A)
11	Config preliminary revision	0=Sharp revision, 1=Preliminary revision	0	Sharp revision
			1	Preliminary revision

**PASSW\_I2C (0xC4)**

Description: Password for I2C

Bit	Description	Format
15:0	Write value 0xC93F to this command to enable I2C register writes. Writing the password to this command is also required for passwords in 0xC5 and 0xC6 to be effective.	Byte Array

**PASSW\_OTP (0xC5)**

Description: Password for OTP

Bit	Description	Format
15:0	Write value 0x4B6A to this command to enable the burn OTP function (0xD6 command). It is also required that the password is written to command 0xC4.	Byte Array

**PASSW\_ADDR (0xC6)**

Description: Password for ADDRESS

Bit	Description	Format
15:0	Write value 0xF1C0 to this command to enable the custom PMBUS base address setting (0xE0 command). It is also required that the password is written to command 0xC4.	Byte Array

**OTP\_WRITE (0xCF)**

Description: Available # of OTP write cycles

Bit	Description	Format
7:0	Returns how many OTP writes that are left. Use before a 0xD6 command write.	Integer Unsigned

**DEVICE\_FULL\_ADDRESS (0xD3)**

Description: Reads PMBus address 8 bit

Bit	Description	Format
7:0	Returns the PMBus device address aligned on 8 bit.	Byte Array

**DCX\_VOUT\_SS\_FAULT (0xD4)**

Description: Soft start rise check step size

Bit	Description	Format
7:0	Enable/disable and specify the incremental step of the monotonic check in Vout mantissa number. The value is Vout_step (value of Vout PMBUS mantissa) where $Vout(n+1) > Vout(n) + Vout\_step$ for a regular soft start. The sampling (n+1) and (n) are defined by the command 0xDF. A value of 0 means monotonic check is disabled. The check is also always disabled when $Vout > 0.5 VOUT\_UV\_FAULT\_LIMIT$ .	Integer Unsigned

**OTP\_UPLOAD (0xD6)**

Description: Store to OTP command

Bit	Description	Format
7:0	In Write mode, it saves the config values from RAM into OTP memory. Use payload 0xAA. PMBus commands are not accepted, wait 120 ms for the writing time. Before command is written, passwords must be written to 0xC4 and 0xC5. In Read mode, it returns 0xCC = written successfully; 0xFF = it's an error.	Byte Array

**NTC\_CS\_LUT\_STATUS (0xD8)**

Description: LUT memory area status

Bit	Description	Value	Function	Description
-----	-------------	-------	----------	-------------

7:0	Returns the status of the LUT memory area: If 0x01, LUT NTC stored If 0x02, LUT CS stored If 0x03, LUT NTC and CS stored	0x00	No LUT stored	No LUT stored.
		0x01	NTC LUT stored	NTC LUT stored.
		0x02	CS Gain LUT stored	CS Gain LUT stored.
		0x03	NTC and CS Gain LUTs stored	NTC and CS Gain LUTs stored.

**DCX\_SS\_PROTECTION (0xDF)**

Description: Defines the sampling instants (n+1) and (n) for the command 0xD4.

Bit	Function	Description	Format	Unit
5:3	Initial sample time	From 0.5 ms [000] to 2.25 ms [111], step 0.25 ms.	Fixed Point Unsigned	ms

Bit	Function	Description	Value	Function	Description
2:0	Pace of samples (n) and (n+1)	From 0.75 ms [011] to 1.75 ms [111], step 0.25 ms.	011	0.75 ms	
			100	1.00 ms	
			101	1.25 ms	
			110	1.50 ms	
			111	1.75 ms	

**PMBUS\_BASE\_ADDRESS (0xE0)**

Description: Sets the PMBUS base address of the address range. If a store failed and with blank part a default base address set equal to 0x1 (16d). Before command is written, passwords must be written to 0xC4 and 0xC6. After write, input voltage must be cycled before the base address is actually changed.

Bit	Description	Format
7:5	Base Address to start from. 000b => base address 0x00, 001b => base address 0x10, 010b => base address 0x20, 011b => base address 0x30, etc.	Fixed Point Unsigned

**NTC\_LUT\_CRC16\_READ (0xE1)**

Description: Reads the checksum value for the NTC LUT.

Bit	Description	Format
15:0	NTC LUT CRC16 value.	Integer Unsigned

**CS\_LUT\_CRC16\_READ (0xE2)**

Description: Reads the checksum value for the CS Gain LUT.

Bit	Description	Format
15:0	CS Gain LUT CRC16 value.	Integer Unsigned

**CHECKSUM\_CRC (0xEE)**

Description: Calculated config file CRC

Bit	Description	Format
15:0	Returns the CRC16 calculated based on the configuration file. At POR and after STORE, the embedded processor compares the CRC16 signature placed in the configuration file with the calculated CRC16. If they don't match, IC enters Recovery mode (no configuration file), triggers the Memory Fault in STATUS_CML and set the PMBUS address to 0xB0.	Direct

**REG\_CON\_OFFSET\_IOUT (0xF0)**

Description: READ\_IOUT calibration offset

Bit	Function	Description	Format	Unit
6:0	READ_IOUT calibration offset value	Setting the offset to the READ_IOUT mantissa: Bit 7 = 0 for positive values and 1 for negative Bit 6:0 = offset of the PMBUS mantissa	Fixed Point Unsigned	A

Bit	Function	Description	Value	Function	Description
7	READ_IOUT calibration offset sign bit	Setting the offset to the READ_IOUT mantissa: Bit 7 = 0 for positive values and 1 for negative Bit 6:0 = offset of the PMBUS mantissa	0	Positive offset	Positive offset.
			1	Negative offset	Negative offset.

**REG\_CON\_MULT\_IOUT (0xF1)**

Description: READ\_IOUT calibration gain

Bit	Description	Format
7:0	Setting the internal gain of the READ_IOUT value.	Fixed Point Unsigned