

APPLICATION NOTE 308

---

# Fault spreading for digital Point of Load regulators

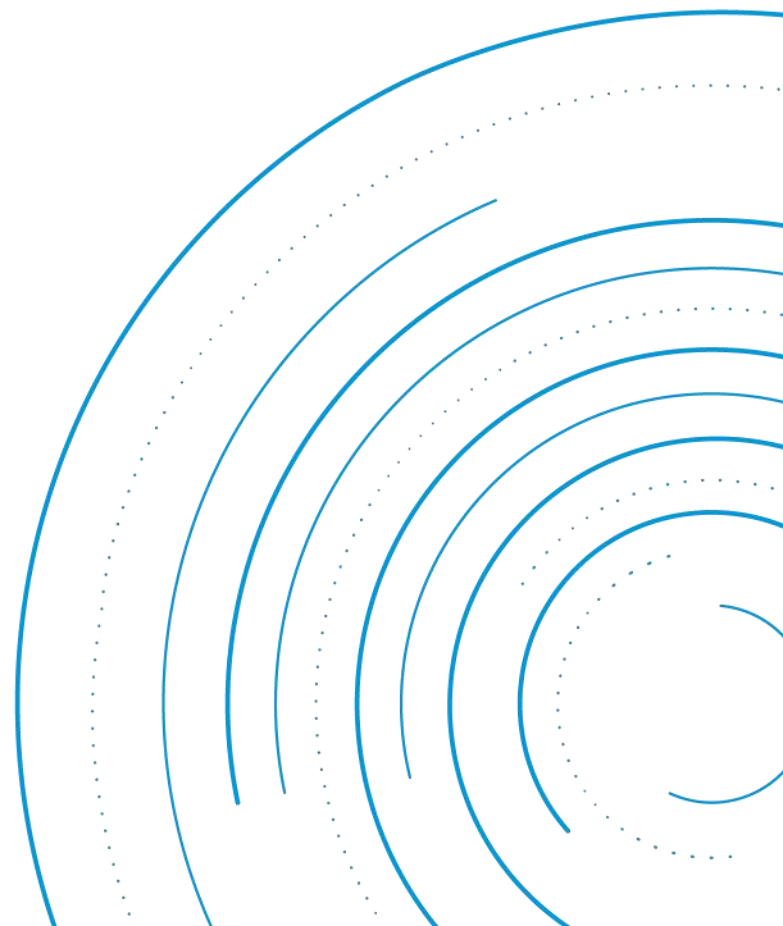

# Abstract

The digital products can be configured, controlled and monitored through a digital serial interface using the PMBus® power management protocol.

This application note provides information on how to use the fault spreading function of the digital PoL regulators.

This application note applies to the following products:

- **BMR462**
- **BMR463**
- **BMR464**
- **BMR465**
- **BMR466**
- **BMR467**
- **BMR469**

# Contents

<b>Fault spreading operations</b> .....	<a href="#">3</a>
Overview .....	<a href="#">3</a>
Introduction to GCB .....	<a href="#">3</a>
Fault spreading shutdown response .....	<a href="#">3</a>
Immediate shutdown example .....	<a href="#">3</a>
Sequenced shutdown example .....	<a href="#">4</a>
Fault spreading recovery .....	<a href="#">4</a>
Fault indication .....	<a href="#">5</a>
<b>Configuration of fault spreading</b> .....	<a href="#">6</a>
Configuration of fault spreading group including only BMR462/463/464/466 .....	<a href="#">6</a>
Configuration of fault spreading group including only BMR465/467/469 .....	<a href="#">6</a>
Configuration of fault spreading group including both BMR465/467/469 and BMR462/463/464/466 .....	<a href="#">7</a>
Disabling fault spreading .....	<a href="#">9</a>
Configuration of fault spreading recovery .....	<a href="#">9</a>
Parallel rails .....	<a href="#">9</a>

# Fault spreading operation

## Overview

Flex Power Modules digital PoL products can be configured to broadcast a fault event on the GCB (Group Communication Bus) bus. When a non-destructive fault occurs and a device is configured to shut down on a fault, the device will shut down and broadcast the fault event on the GCB bus. Other devices on the same GCB bus will shut down together if configured to do so, and will attempt to re-start in their prescribed sequencing order if configured to do so.

## Introducing the GCB

Flex Power Modules digital PoL products have a dedicated single wire serial bus (GCB bus) to synchronize and communicate real-time events. This is an internal bus which is only connected across modules and not to the PMBus system host. GCB addresses are assigned on a rail level, i.e. devices within the same current sharing group share the same GCB address.

Addressing rails across the GCB is done with a 5 bit GCB ID, yielding a theoretical total of 32 rails that can be shared with a single GCB bus. For reliable operation GCB signal integrity has to be maintained. It is especially critical when using multiple devices on the bus spread on a large board area as they might create a large capacitive load slowing the signals down. The GCB signal rise time has to be maintained to meet the criteria described by the rise time equation in the product's Technical Specification.

During GCB events, all devices will receive messages but only those devices configured to respond will do so. Multiple current sharing groups and power rails can communicate over the same GCB bus.

## Fault spreading shutdown response

Our digital PoL products can be operated with two different fault spreading shutdown response:

1. Immediate shutdown: A rail will respond to a fault event on the GCB bus by an immediate shutdown of its output voltage.
2. Sequenced shutdown: A rail will respond to a fault event on the GCB bus by a sequenced shutdown according to its position in a configured power-up sequence. This mode of operation requires that GCB based sequencing is configured (see [AN310](#)).

**Note!** Sequenced shutdown is not supported for BMR465/BMR467/BMR469 multiple devices operating in parallel configuration (current sharing), BMR469 single module 2 phases in parallel supports sequenced shutdown.

A group of rails configured for both GCB based sequencing and fault spreading should all use the same fault spreading shutdown response - immediate shutdown or sequenced shutdown.

## Immediate shutdown example

A fault spreading group of three rails is configured for immediate shutdown. Figure 4 shows how output voltages shut down in the case where Rail 1 faults.

Rails 2 and 3 shut down in immediate response to a fault event sent from Rail 1. The delay  $t_{SPREAD}$  is a propagation delay that is occurring due to internal time delays of each device, needed to send and respond to GCB fault events.  $t_{SPREAD}$  depends on the products used and will typically vary in the range 2-10 ms

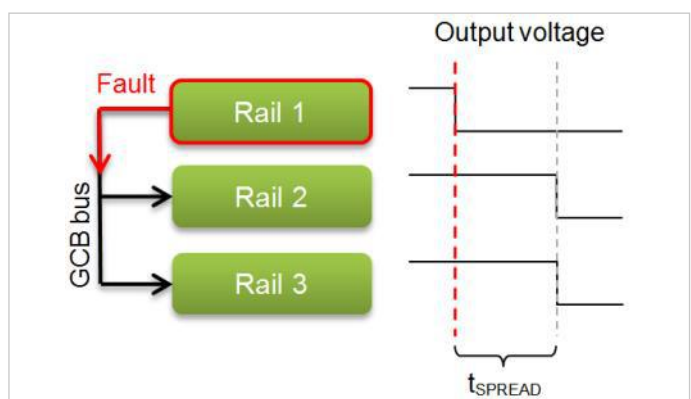

Picture 1: Operation of fault spreading example—immediate shutdown

## Sequenced shutdown example

A group of five rails is configured for GCB based sequencing with the power-up order Rail 1 -> Rail 2 -> Rail 3 -> Rail 4 -> Rail 5. For simplicity it is assumed that the sequencing timing between each rail,  $t_{SEQ}$  (delay+ ramp time, see [AN310](#)), is the same for all rails.

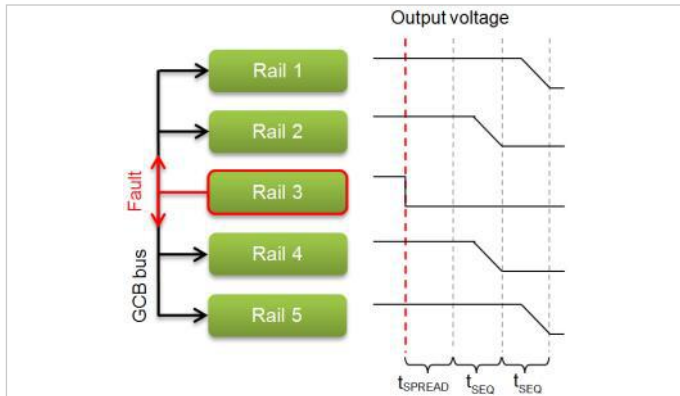

Picture 2: Operation of fault spreading example—sequenced shutdown

Figure 2 shows how output voltages shut down in the case where Rail 3 faults. As seen the rails will sequence down in both directions from the failed rail, based on the configured power-up order. The delay  $t_{SPREAD}$  before sequencing starts is due to internal time delays of each device, needed to send and respond to GCB fault events.  $t_{SPREAD}$  depends on the products used and will typically vary in the range 2-10 ms.

## Fault spreading recovery

**Note!** Fault spreading recovery is not fully supported for phase spreading groups that include BMR465/BMR467/BMR469 based rails. See chapter *Configuration of Fault Spreading*.

### Rails not using GCB based sequencing

A rail not configured for GCB based sequencing, responding to a GCB fault spreading event, will restart according to the faulting rail's fault response setting for the fault type that occurred. Thus, a restart event is broadcasted on the GCB bus by the faulting device if it is configured for restart.

### Example: rails not using GCB based Sequencing

This example is illustrated by the oscilloscope capture in Figure 6. Rail 1 is configured to restart automatically after an over current fault (MFR\_IOUT\_OC\_FAULT\_RESPONSE = 0xBF). When an overcurrent fault occurs for Rail 1, it broadcasts a fault event on the GCB bus. Rail 2 receives the fault event and shuts down (immediately). The faulting Rail 1 is configured for restart and when it is about to restart it will broadcast a restart event on the GCB bus. Since Rail 2 is configured to respond to fault events from Rail 1, it will also respond to the restart event from Rail 1 and make a restart attempt of its output voltage. Note that the overcurrent fault response setting for Rail 2 does not have an impact on Rail 2 whether it will restart or not in this case, since it is controlled by restart event from Rail 1.

Due to internal time delays of devices, needed to send and respond to GCB events, Rail 2 will restart at a later point in time compared to Rail 1 (both rails have the same ramp-up settings).

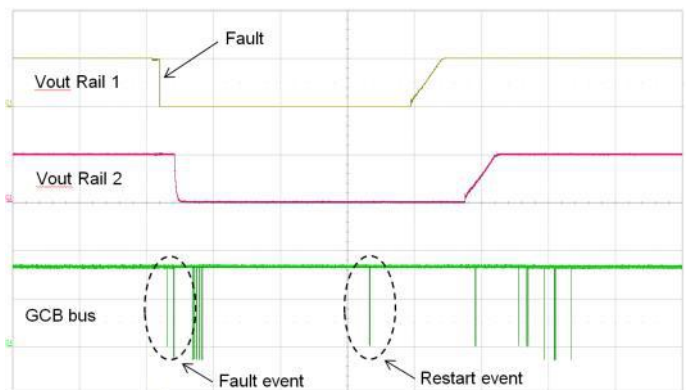

Picture 3: Fault spreading recovery - devices not using GCB sequencing (immediate shutdown). 20 ms/div

### Rails using GCB based sequencing

Rails configured for GCB based sequencing and fault spreading will restart output voltages according to the configured power-up sequence if the fault response setting of the faulting rail is set to restart (retry). This applies regardless of which rail in the sequence order faulted and broadcasted the fault event. This also applies regardless of immediate or sequenced shutdown response of the configured fault spreading.

## Example: Rails using GCB based sequencing

This example is illustrated by the oscilloscope capture in Figure 4. A GCB sequencing group with power-up order Rail 1 -> Rail 2 -> Rail 3. Rails are configured for fault spreading with sequenced shutdown. Rail 3 is configured to restart automatically after an over current fault (MFR\_IOUT\_OC\_FAULT\_RESPONSE = 0xBF).

When an overcurrent fault occurs for Rail 3, it sends a fault event on the GCB bus. Rails 1 and 2 receive the fault event and shut down in sequence (in direction from the faulting Rail 3). Since Rail 3 is configured for restart it will broadcast a restart event on the GCB bus. This event will trigger Rail 1, being the first rail in the power-up sequence, to restart. GCB sequencing will then follow with Rails 2 and 3 also ramping up.

**Note** that the overcurrent fault response setting for Rail 1 and 2 has no impact whether these rails will restart or not in this case, since they are controlled by restart event from Rail 3.

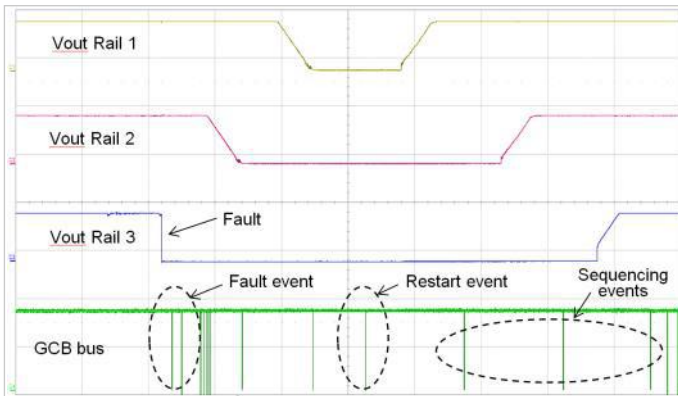

Picture 4 : Fault spreading recovery - devices using GCB sequencing (sequenced shutdown). 20 ms/div

## Fault indication

In a fault spreading group only the rail that faulted and initiated the shutdown will report a fault via its status registers (e.g. PMBus commands STATUS\_BYTE and STATUS\_WORD). Rails shutting down only due to a received GCB fault event do not report any fault.

# Configuration of fault spreading

## Configuration of a fault spreading group including only BMR462/BMR463/464/BMR466

Fault spreading is configured by the following PMBus commands. An example is shown in Table 1 on the next page.

### GCB\_CONFIG

Each rail in the fault spreading group must have its unique GCB ID set by bits [4:0]. Further, GCB TX Inhibit bit [5] must be set to 0. If Flex Power Designer is used to create a configuration, these settings are made automatically. GCB ID=0 is recommended not to use, to avoid conflicts for those modules were not included in the Flex Power Designer but actually connected to the GCB bus.

### GCB\_GROUP

Defines which rails' fault events should be responded to. Setting bit #0 to 1 means fault events from rail with GCB ID= 0 will be responded to. Setting bit #1 means fault events from rail with GCB ID = 1 will be responded to, and so on.

Multiple bits can be set so a device would respond to faults of multiple rails.

### USER\_CONFIG

Bit [8] selects response to immediate shutdown (bit=1) or sequenced shutdown (bit=0). If sequenced shutdown is selected, a GCB based sequencing must be configured by the command SEQUENCE and other related commands, see AN310 for details. A group of rails configured for both fault spreading and GCB based sequencing should all use the same shutdown response (immediate or sequenced).

GCB TX	GCB ID	Shutdown response	Response to fault event
Setting	Do not inhibit		Immediate
			Each rail will respond to fault events from the other 2 rails

	GCB_CONFIG (5)	GCB_CONFIG (4:0)	USER_CONFIG (8)	GCB_GROUP
Rail 1— BMR463	0	0b00000 (ID = 0)	1	0x0006 (bits #1 and #2 set)
Rail 2— BMR464	0	0b00001 (ID = 1)	1	0x0005 (bits #0 and #2 set)
Rail 3— BMR466	0	0b00010 (ID = 2)	1	0x0003 (bits #0 and #1 set)

Table 1: Fault spreading configuration example with BMR462-464 and BMR466

## Configuration of a fault spreading group including only BMR465/BMR467/BMR469

Fault spreading is configured by the following PMBus commands. An example is shown in Table 2.

### GCB\_CONFIG

Each rail in the fault spreading group must have its unique GCB ID set by bits [12:8]. If Flex Power Designer is used to create a configuration, this setting is made automatically. GCB ID=0 is recommended not to use, to avoid conflicts for those modules were not included in the Flex Power Designer but actually connected to the GCB bus.

## GCB\_GROUP

Bits [4:0] defines a Fault Spreading Group ID (0-31) and controls which rails' fault events should be responded to. A rail with a certain Fault Spreading Group ID set will respond to fault events from other rails which has the same Fault Spreading Group ID set.

**Note!** Rails configured for GCB based sequencing will always respond to each others fault events, regardless of the Fault Spreading Group ID setting.

Bit [5] selects response to immediate shutdown (bit=1) or sequenced shutdown (bit=0). If sequenced shutdown is selected, a GCB based sequencing must be configured by the command SEQUENCE and other related commands, see [AN310](#) for details. A group of rails configured for both fault spreading and GCB based sequencing should all use the same shutdown response (immediate or sequenced).

## Configuration of a fault spreading group including both BMR462-464/BMR466 and BMR465/BMR467/BMR469

When mixing the two type of products an additional command LEGACY\_FAULT\_GROUP must be configured for the BMR465/BMR467/BMR469 devices in order to respond to faults events from BMR462-464/BMR466.

GCB TX	GCB ID		Shutdown response	Response to fault event			
Setting	Do not inhibit		sequenced	Each rail will respond to fault events from the other two rails (all rails assigned to Fault Spreading Group with ID=2).			

	GCB_CONFIG (5)	GCB_CONFIG[4:0]	GCB_CONFIG[12:8]	USER_CONFIG (8)	GCB_GROUP [5]	GCB_GROUP	LEGACY_FAULT_GROUP	GCB_GROUP [4:0]
Rail 1— BMR463	0	0b00000 (ID = 0)		0		0x000E (bits #1, #2, #3 set)		
Rail 2— BMR464	0	0b00001 (ID = 1)		0		0x000D (bits #0, #2, #3 set)		
Rail 3— BMR465			0b00010 (ID = 2)		0		0x0003 (bits #0, #1 set)	0b00010 (Spreading ID = 2)
Rail 4— BMR465			0b00011 (ID = 3)		0		0x0003 (bits #0, #1 set)	0b00010 (Spreading ID = 2)

Table 1: Fault spreading configuration examples

## LEGACY\_FAULT\_GROUP

Defines which rails' fault events should be responded to. Setting bit #0 means fault events from rail with GCB ID = 0 will be responded to. Setting bit #1 means fault events from rail with GCB ID = 1 will be responded to, and so on.

An example is shown in Table 3. For example Rail 4 has bits in LEGACY\_FAULT\_GROUP corresponding to GCB IDs 0 and 1 set in order to respond to faults from Rail 1 and Rail 2, and GCB\_GROUP[4:0] set to same Fault Spreading Group ID as Rail 3 in order to respond to faults from Rail 3

GCB ID	Shutdown response	Response to fault event
Setting	Do not inhibit	Immediate
		Each rail will respond to fault events from the other two rails (all rails assigned to Fault Spreading Group with ID=2).

	GCB_CONFIG (12:8)	GCB_GROUP (5)	GCB_GROUP (4:0)
Rail 1—BMR465	0b00000 (ID = 0)	1	0b00010 (Fault Spreading Group ID = 2)
Rail 2—BMR465	0b00001 (ID = 1)	1	0b00010 (Fault Spreading Group ID = 2)
Rail 3—BMR467	0b00010 (ID = 2)	1	0b00010 (Fault Spreading Group ID = 2)

Table 2: Fault spreading configuration examples

## Disabling Fault Spreading

For BMR462-464/BMR466 products fault spreading is disabled by setting GCB\_GROUP = 0x0000, which is the default setting.

For BMR465/BMR467/BMR469 products fault spreading is disabled by setting LEGACY\_FAULT\_GROUP = 0x0000 and GCB\_GROUP [5] = 0 (sequenced shutdown set), which are the default setting.

**Note!** BMR465/BMR467/BMR469 rails being part of the same GCB based sequencing group will always respond to each others fault events, thus fault spreading between these rails cannot be disabled.

## Configuration of fault spreading recovery

Control of restart is made by the individual FAULT\_RESPONSE\_x commands for each fault type. Refer to the Technical Specification of the product or [AN302](#). For sequenced restart, GCB based sequencing must be configured, see [AN310](#) for details.

**Note!** Fault spreading recovery is not fully supported for BMR465/BMR467/BMR469 rails. Therefore, it is recommended to use latched fault response (Disable, No retry; FAULT\_RESPONSE\_x = 0x80) for all rails in fault spreading groups that include BMR465/BMR467/BMR469 rails.

## Parallel rails

Fault spreading is supported also for devices operating in parallel configuration (current sharing rails). Each device in the parallel rail must have the same settings for the PMBus commands related to fault spreading (see above). See [AN307](#) for further details.

**Note!** BMR465/BMR467/BMR469 multiple module parallel rails do not support sequenced shutdown.

BMR469 single module 2 phases parallel operation rail support sequenced shutdown.

**Note!** BMR465/BMR467/BMR469 rails cannot be operated on the same GCB bus as parallel rails of DLC variants of BMR463-464/BMR466 (see ordering info in product's TS). Thus these type of rails cannot be part of the same fault spreading group.

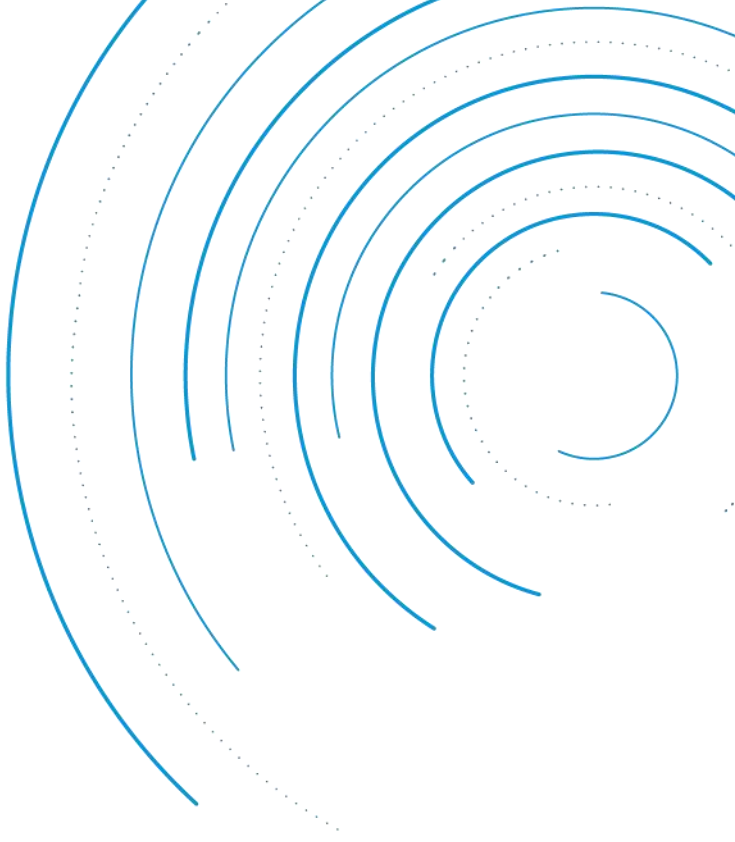







# flex<sup>®</sup> Power Modules

Flex Power Modules, a business line of Flex, is a leading manufacturer and solution provider of scalable DC/DC power converters primarily serving the data processing, communications, industrial and transportation markets. Offering a wide range of both isolated and non-isolated solutions, its digitally-enabled DC/DC converters include PMBus compatibility supported by the powerful [Flex Power Designer](#). Further information can be found at [flexpowermodules.com](http://flexpowermodules.com) or on [LinkedIn](#).

**EMEA (Headquarters)** | Torshamnsgatan 28 A, 16440 Kista, Sweden

**APAC** | 33 Fuhua Road, Jiading District, Shanghai, China 201818

**Americas** | 6201 America Center Drive, San Jose, CA 95002, USA

-  [pm.info@flex.com](mailto:pm.info@flex.com)
-  [twitter.com/flexpowermodule](https://twitter.com/flexpowermodule)
-  [flexpowermodules.com](http://flexpowermodules.com)
-  [flexpowermodules.com/wechat](http://flexpowermodules.com/wechat)
-  [flexpowerdesigner.com](http://flexpowerdesigner.com)
-  [linkedin.com/showcase/flex-power-modules](https://linkedin.com/showcase/flex-power-modules)
-  [youtube.com/flexintl](https://youtube.com/flexintl)

The content of this document is subject to revision without notice due to continued progress in methodology, design and manufacturing. Flex shall have no liability for any error or damage of any kind resulting from the use of this document.